

# inDENSE™

Gravimetric Selection Technology



## inDENSE™

World Water Works' inDENSE system increases process throughput and performance through the selection of dense sludge aggregates with improved settling rates and the promotion of enhanced biological phosphorus removal (EBPR).

inDENSE is a gravimetric selection technology that provides a method for retaining the denser biomass while wasting out the lighter fraction of the MLSS in the treatment system. Increased density can lead to improved settling characteristics which allows for the prevention of biomass loss and subsequent treatment disruptions, especially during wet weather scenarios.

Selection for faster settling particles, process configuration, and physical forces can encourage aerobic granular sludge formation. Hydrocyclones function by forcing denser flocs/solids to the cyclone walls and down through the underflow to be recycled while the lighter solids move towards the cyclone center and are pushed upwards through the overflow to be wasted. With the use of an external mechanism for selective sludge wasting and biological process configuration, facilities can gain improved operation for a **low capital cost investment**.

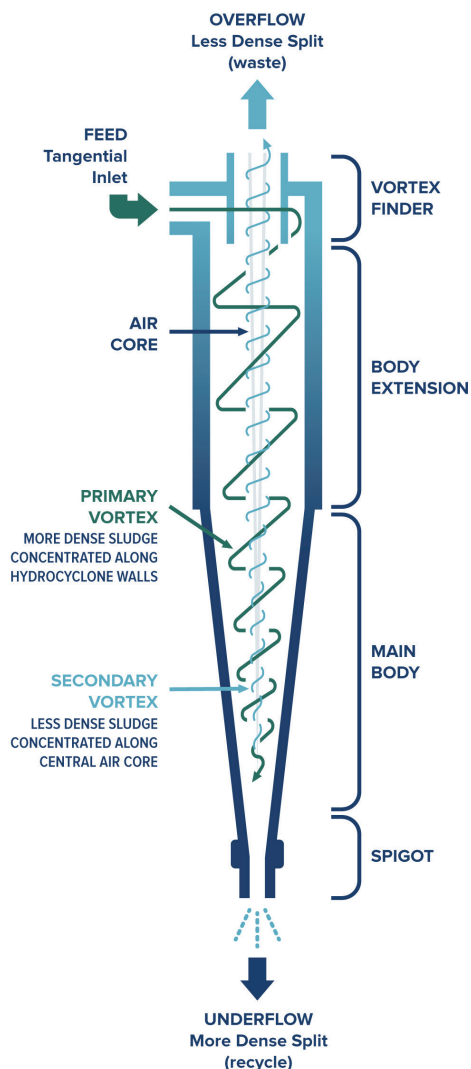

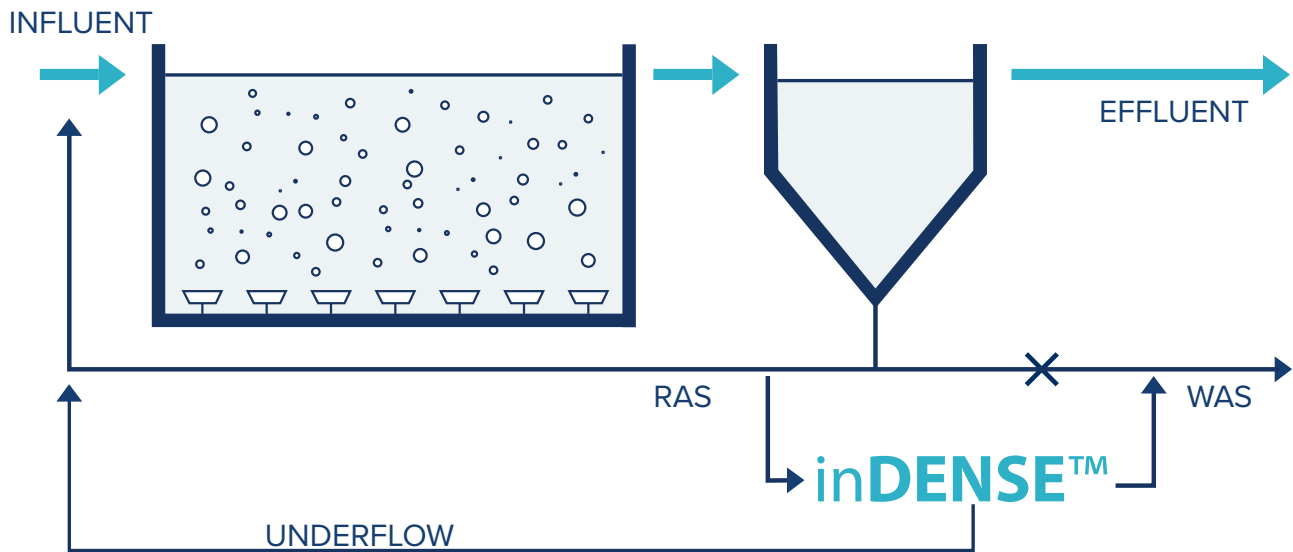

## Benefits

- 💧 Enhanced nitrogen and phosphorus removal
- 💧 Promotes denser sludge selection
- 💧 Solution for poor settling MLSS
- 💧 Reduced and/or eliminated chemistry
- 💧 Easily integrated into any existing plant
- 💧 Rapid return on investment
- 💧 Minimization of sludge loss
- 💧 Operational stability

Conventional activated sludge (CAS) is the predominant wastewater treatment technology globally. One key requirement of the CAS technology is the ability to effectively separate the liquid and solid fractions. Unfavorable settleability can plague facilities seasonally or can be a chronic issue. World Water Works' inDENSE technology helps alleviate this problem.

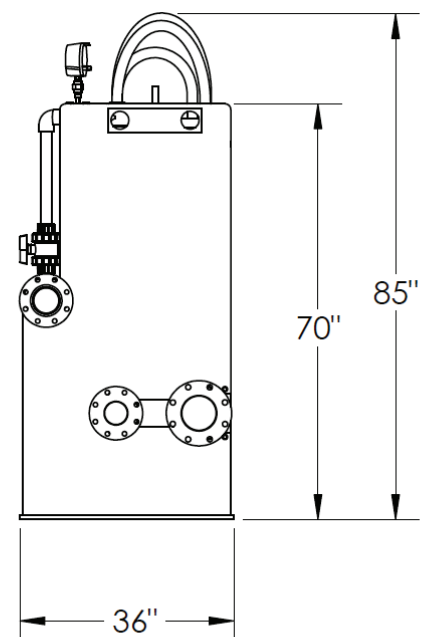
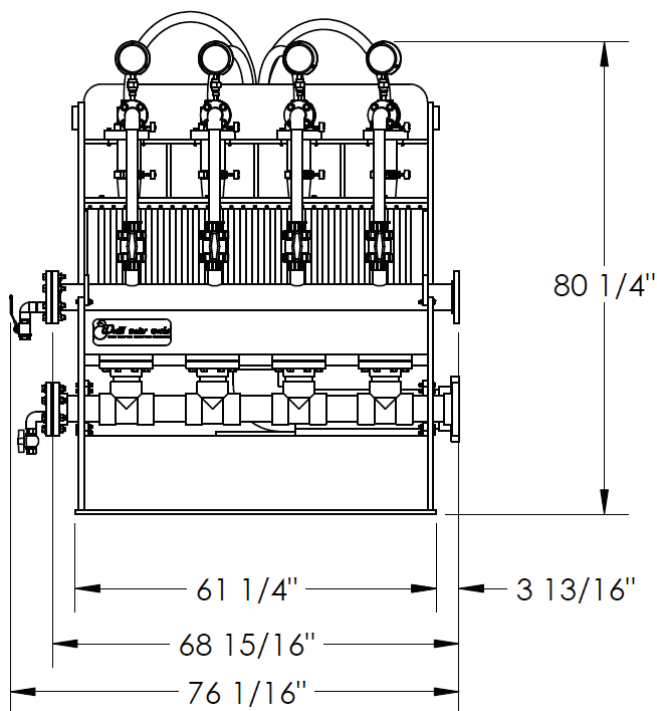

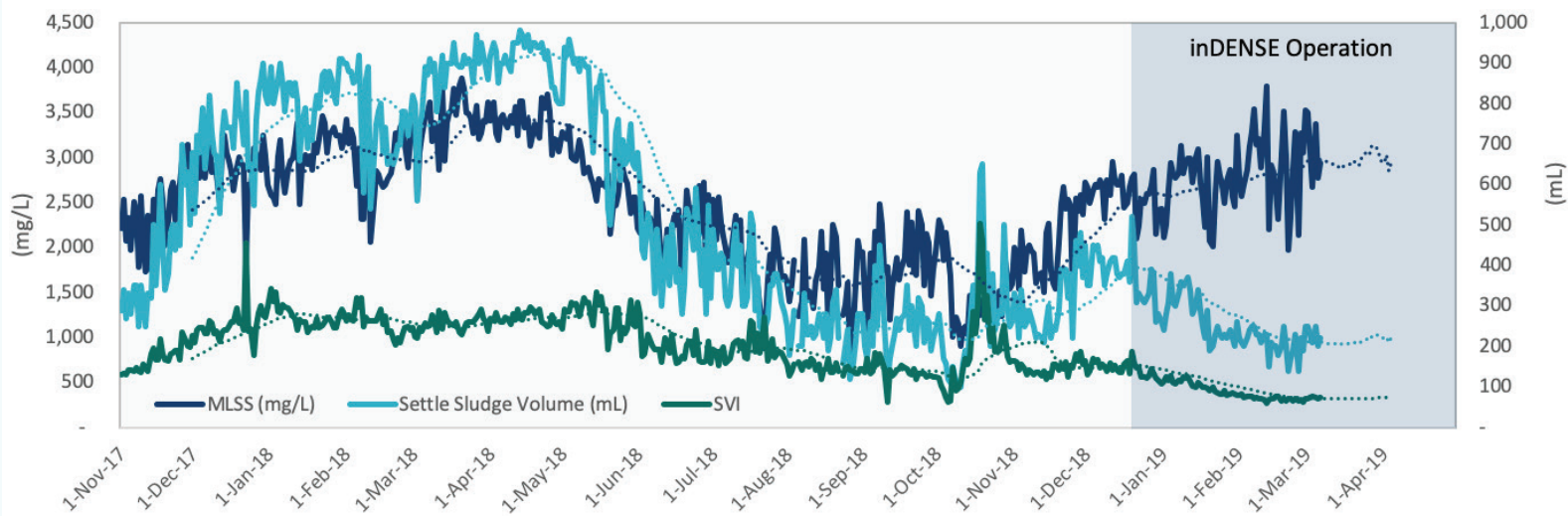

The graph above shows performance of an activated sludge system before and after installation of the inDENSE Process. Once operational, there was an immediate reduction in the Settle Sludge Volume (SSV) and sludge

volume index (SVI) with increase MLSS concentrations. Other process modifications were recommended and implemented by plant staff. The SVI is consistently in high 70's low 80's.

**World Water Works, Inc. is a highly focused company in the wastewater treatment sector. We are driven to provide industrial and municipal customers proven and cost-effective wastewater treatment solutions delivering superior effluent quality.**

We are a passionate and adaptable company providing value through expertly engineered products and technologies. Founded in 1998, we have unparalleled depth of application knowledge and experience.

We have offices located throughout the US, India, and UAE with a fully integrated in-house manufacturing facility at our headquarters in Oklahoma City, OK. This strategically positions us to control schedule while delivering the highest quality products and solutions at the lowest cost of ownership. Working hand-in-hand with our customers, we optimize wastewater treatment solutions globally.

**We at World Water Works are ensuring our wastewater treatment systems meet today's challenges while preparing for tomorrow's water needs.**