



# 2021 GREEN INFRASTRUCTURE DESIGNER SURVEY

RESULTS AND LEARNINGS TO CONSIDER

**Rob Woodman, PE, NGICP, CPESC - National Urban Green Infrastructure Manager**

**Ben Miller, PE – Business Development Manager – Waterworks Infrastructure**



# ROB WOODMAN, P.E.



- Consulting engineer for 10 years
- Engineered solutions specialist for 8 years
- Supported engineers, landscape architects, municipalities and city scale GSI programs
- Developed a VLOG - LidBIT
- Perform 3<sup>rd</sup> party inspections on a wide variety of SWM BMPs throughout Southern Maine.
- Had the opportunity to see and observe many challenges that go beyond the typical engineering plan



# BEN MILLER, P.E.



- General contractor/construction manager for 13 years
- All water, wastewater, and stormwater projects
- Almost all collaborative delivery projects, primarily construction manager at-risk delivery
- Big proponent of collaboration and early contractor/supplier involvement
- Professional engineer in MD, Associate DBIA, Envision-SP; WEF MARC committee member



# FERGUSON WATERWORKS LOCATIONS

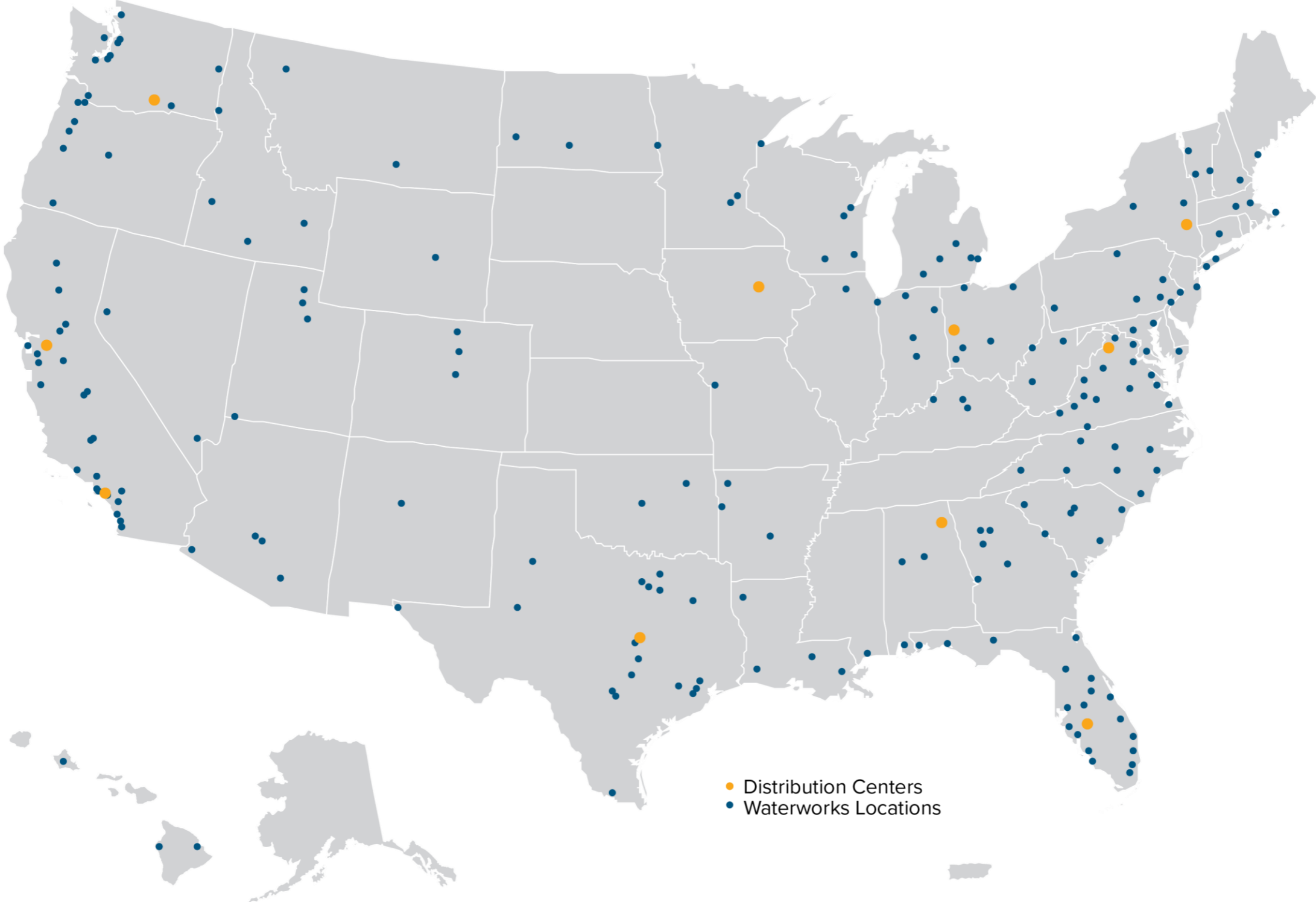

# THE WHY?

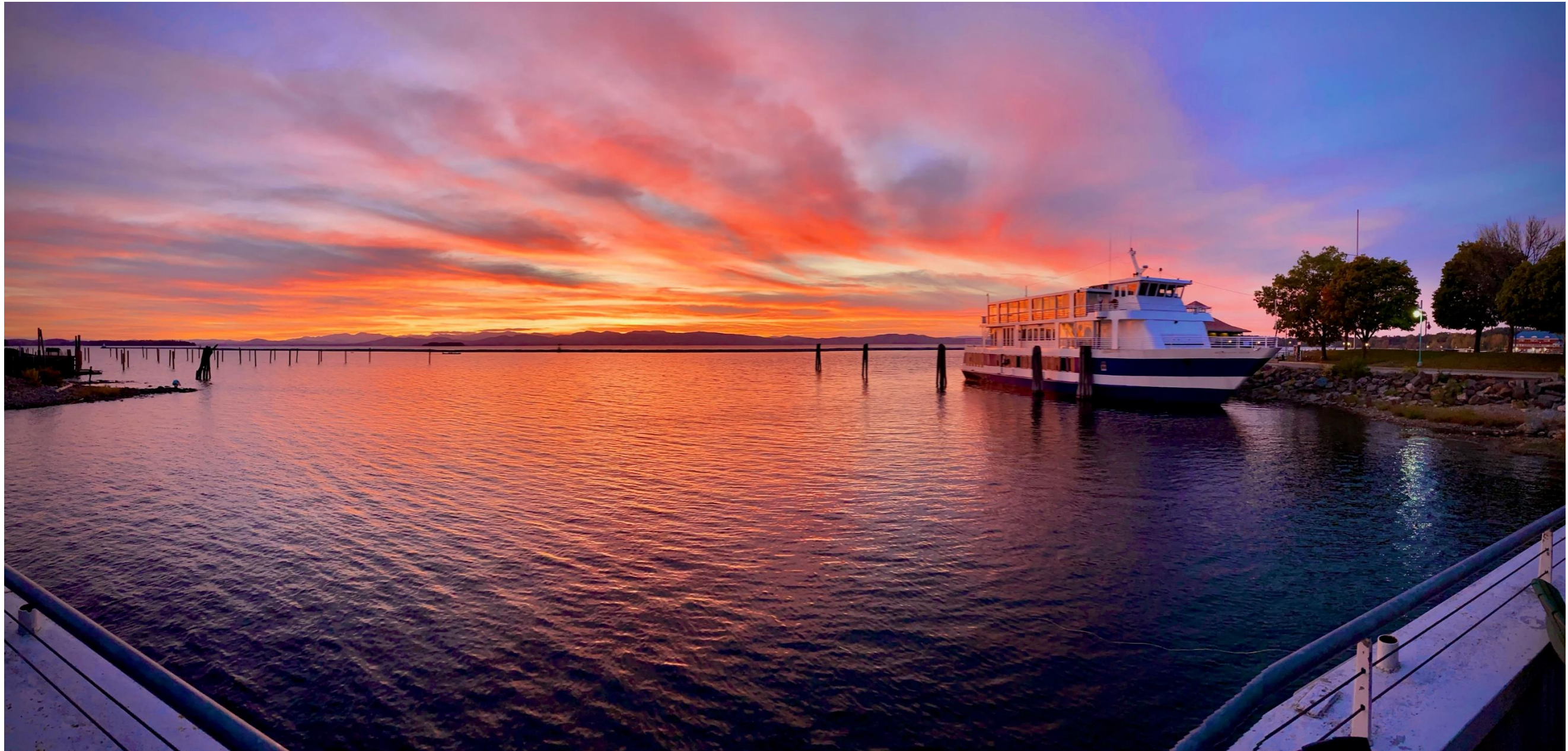

# GREEN STREETSCAPES



26



Existing Conditions



Rendering of New Landscaping Design and Underground Stormwater Storage Area  
(section view; approximately three years after planting)



# EACH CITY HAS THEIR OWN TAKE

## CITY SCALE GI PROGRAMS

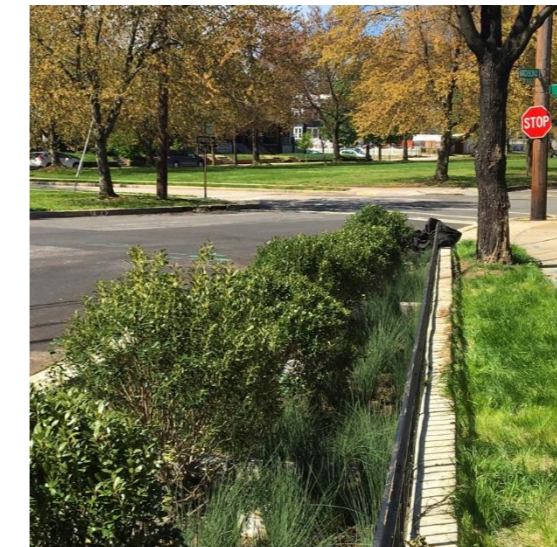

# URBAN COMPLEXITIES

- Tight spaces
- Working around existing infrastructure
- Construction affecting local businesses
- Long term monitoring and metrics
- Need for function and feature / aesthetics
- Often research, design and maintenance are mutually exclusive. i.e. are we taking what we learn in the field back to the next design

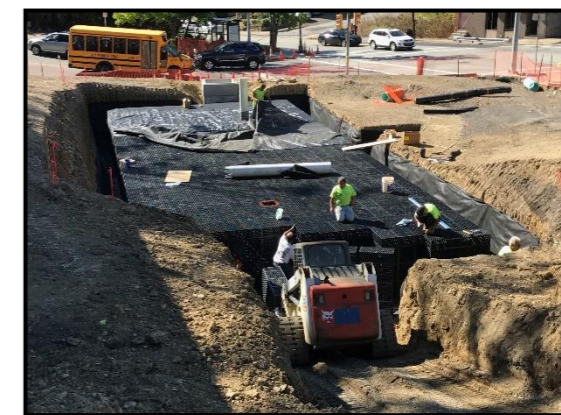



# COLLABORATION SHORTCOMINGS

- Interactions between Owner and designers
- Interactions between design team members
- Quality of bid documents
- Lack of communication/oversight in field
- Post construction maintenance protocols

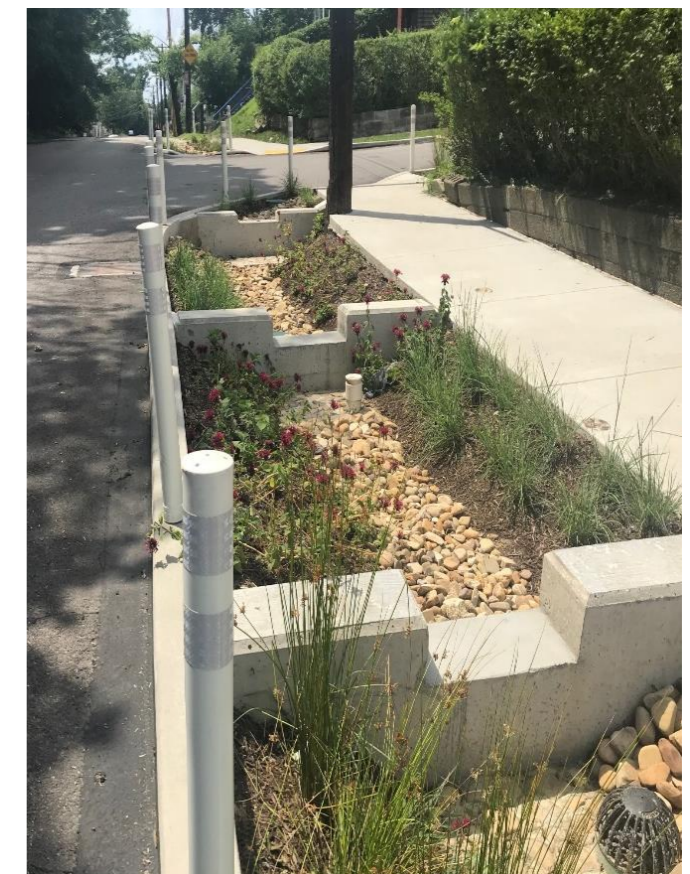
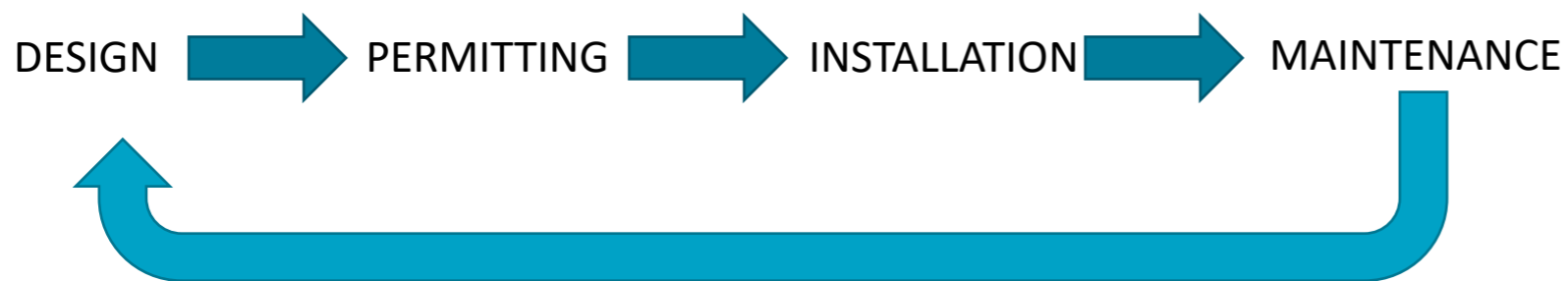

# COLLABORATION SHORTCOMINGS



# THE SURVEY

- Created to get useful feedback from the design community
- Great response from designers
- Questions aren't perfect and answer options were simple
- Addressed design process, construction, maintenance and overall connectivity
- Confirmed several items I was expecting – but hoping weren't true....



## The 2021 GSI Designer Survey

Collecting data to help educate on the improvement needed in green stormwater infrastructure (GSI) design and collaboration

\* Required

What is your email address? \*

Your answer

Are you a \*

- Civil Engineer
- Landscape Architect
- Municipal Planner
- Other

# QUESTION 2

ARE YOU A....

- Civil Engineer
- Landscape Architect
- Municipal Planner
- Other

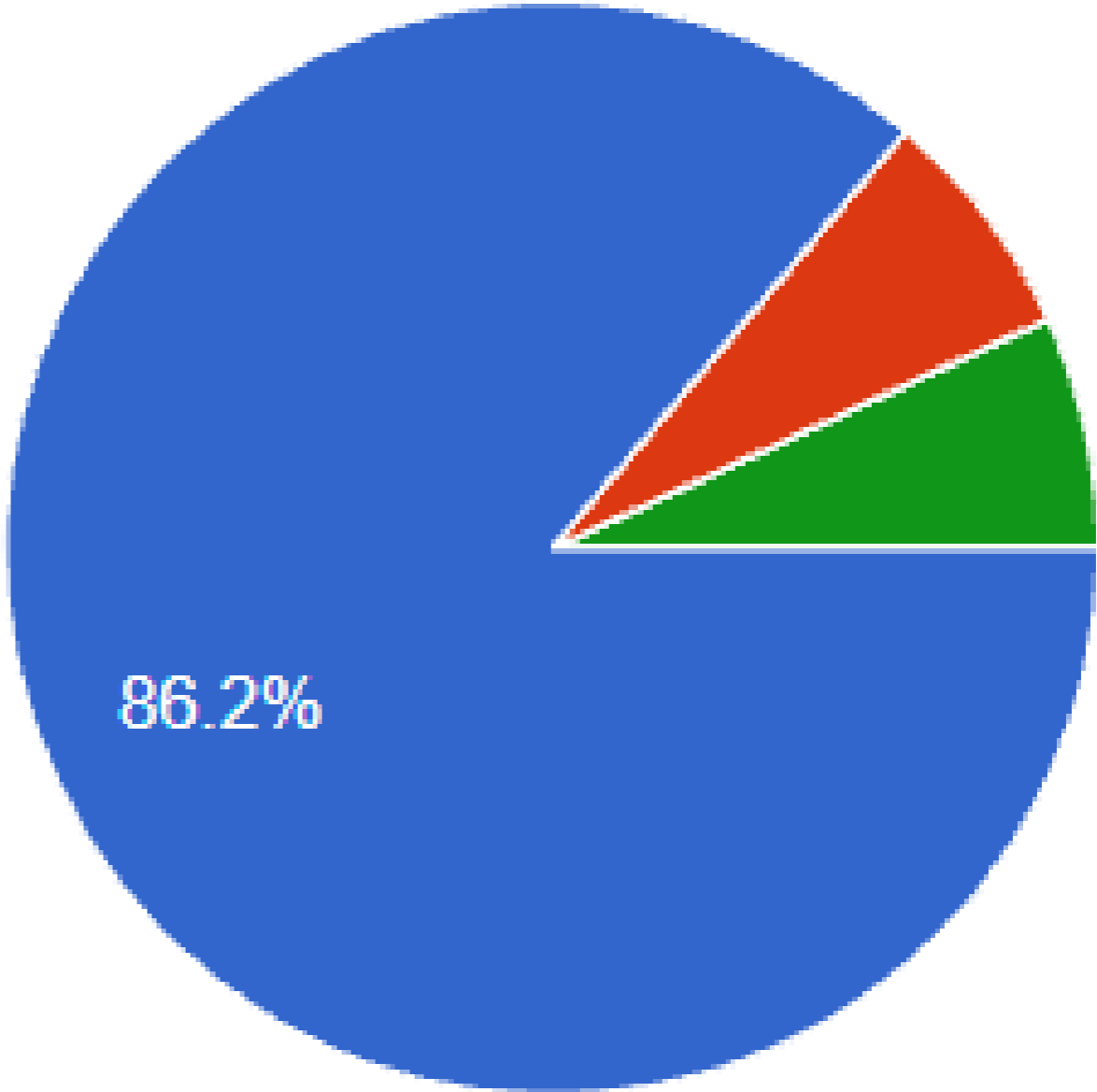

# QUESTION 4

HOW MANY YEARS EXPERIENCE DO YOU HAVE?

- 0 - 5 years
- 6-10 years
- 11-15 years
- More than 15 years

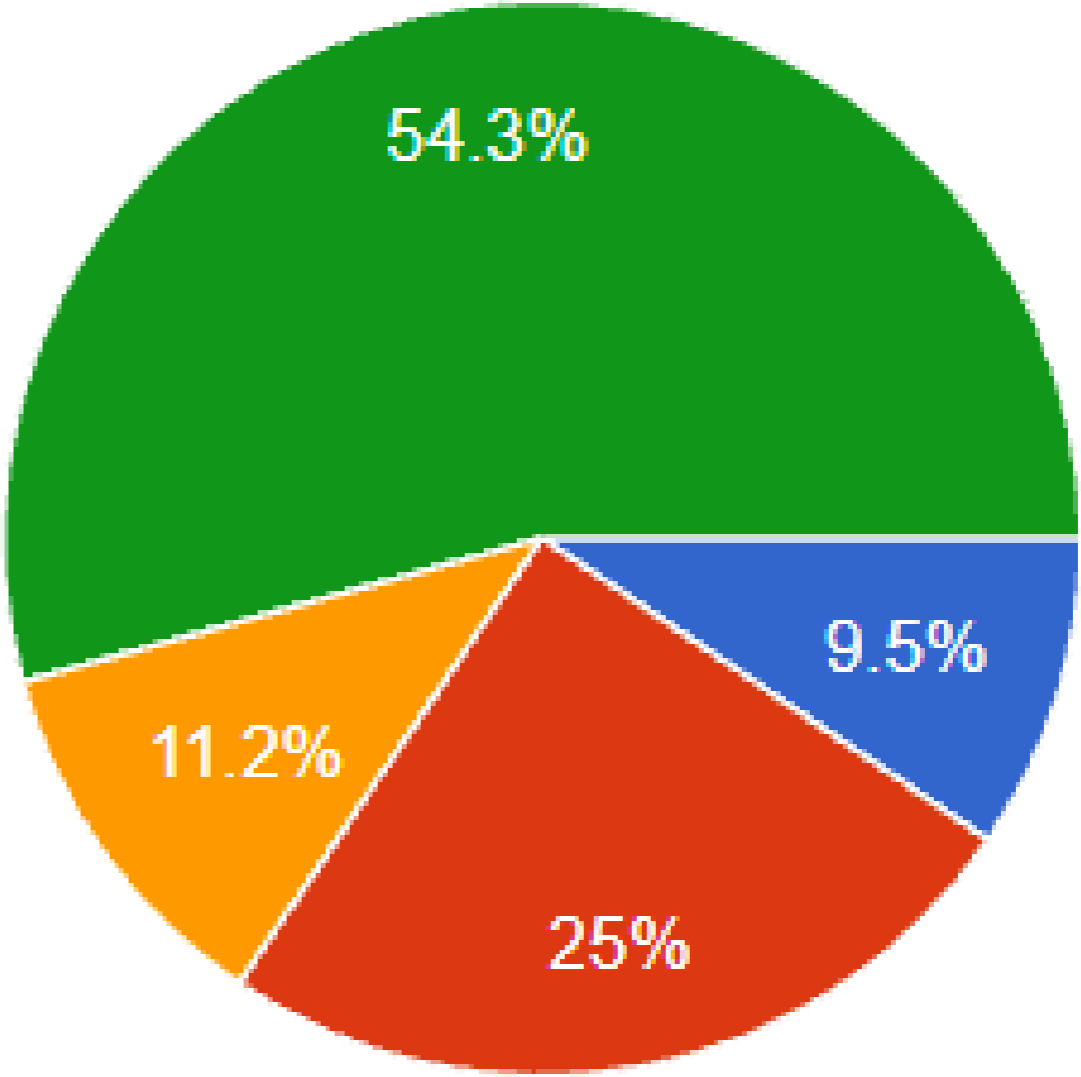

# QUESTION 6

WHAT IS THE PRIMARY GOAL OF YOUR GSI DESIGNS

- Water Quantity management
- Water Quality Treatment
- Both Quantity and Quality
- Streetscape Beautification only

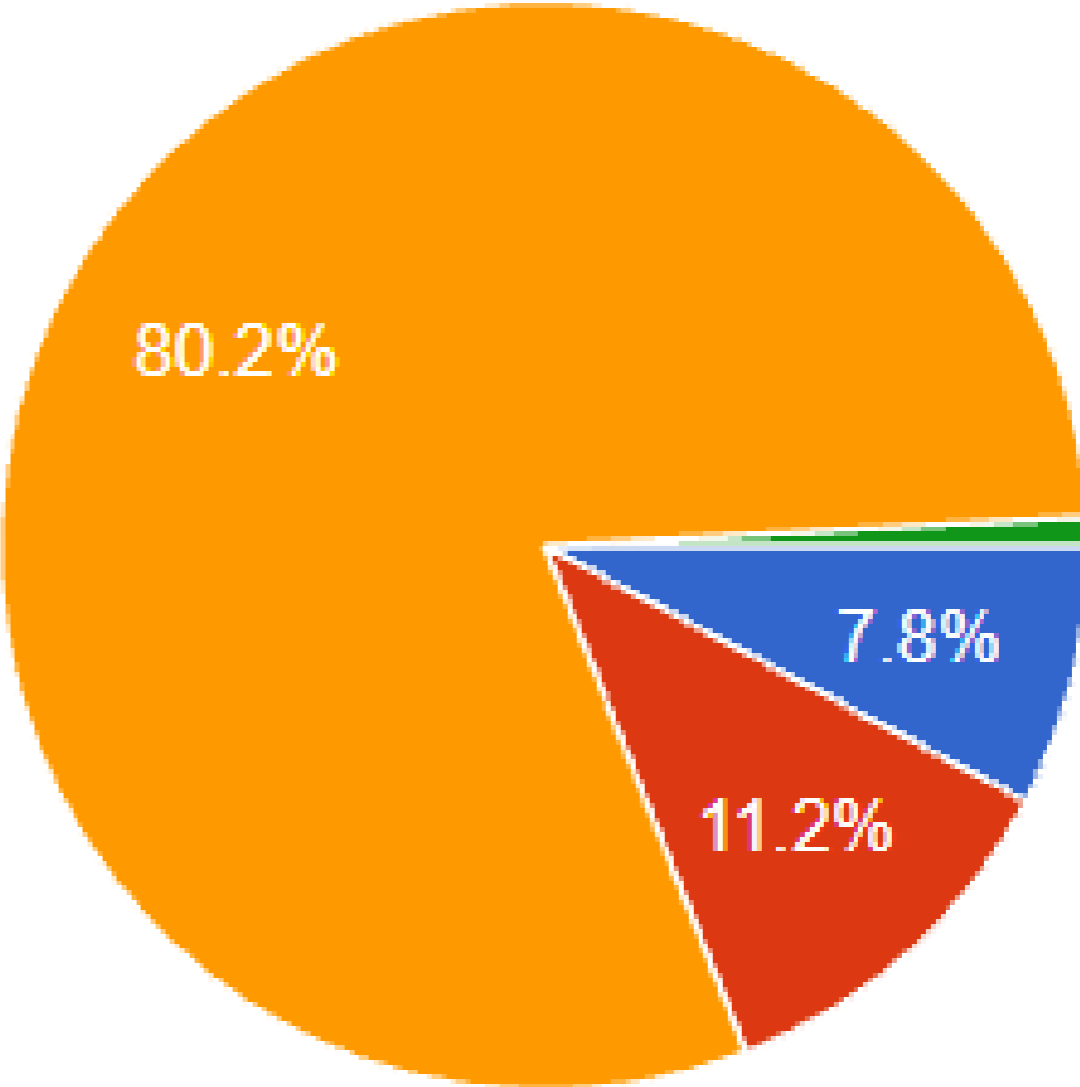

# QUESTION 7

FOR WQ PROJECTS WHAT POLLUTANTS ARE YOUR MOSTLY DESIGNING TO TREAT?

- Trash and Debris
- TSS (total suspended solids)
- TSS and Nutrients - Phosphorus, Nitrogen etc
- Heavy metals
- Bacteria

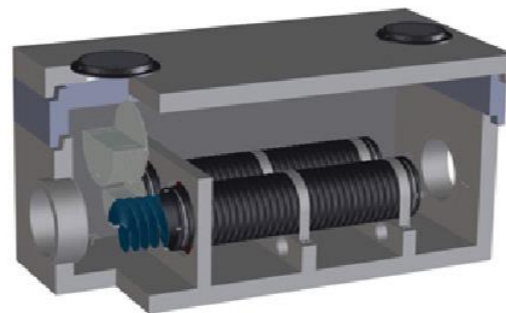
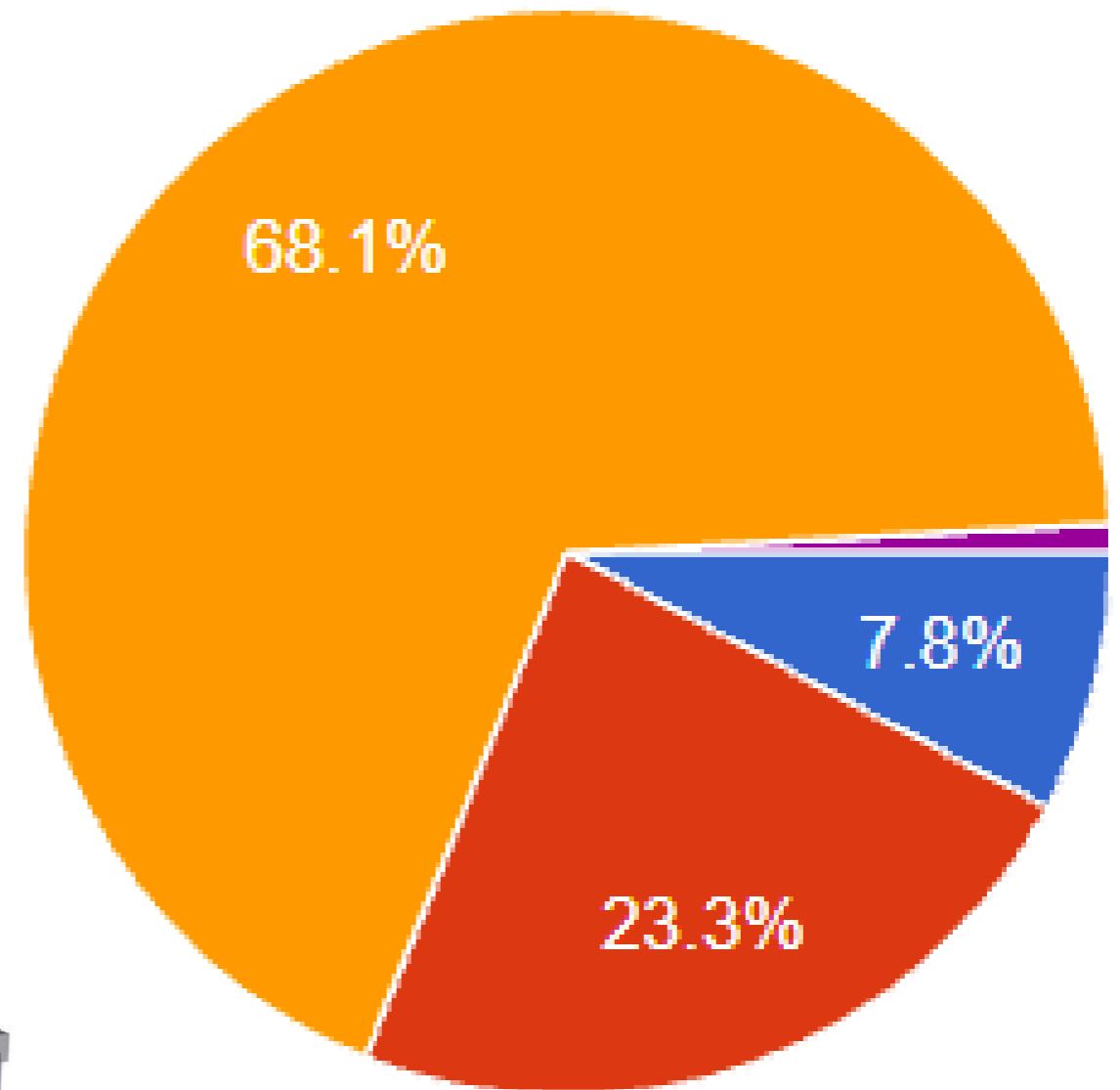

# QUESTION 8

ARE YOU PASSIONATE ABOUT THE CONNECTION BETWEEN YOUR DESIGN WORK AND DEFENDING DOWNSTREAM NATURAL RESOURCES?

- Yes I am!
- Kinda
- Not at all - it is just what I do for a job

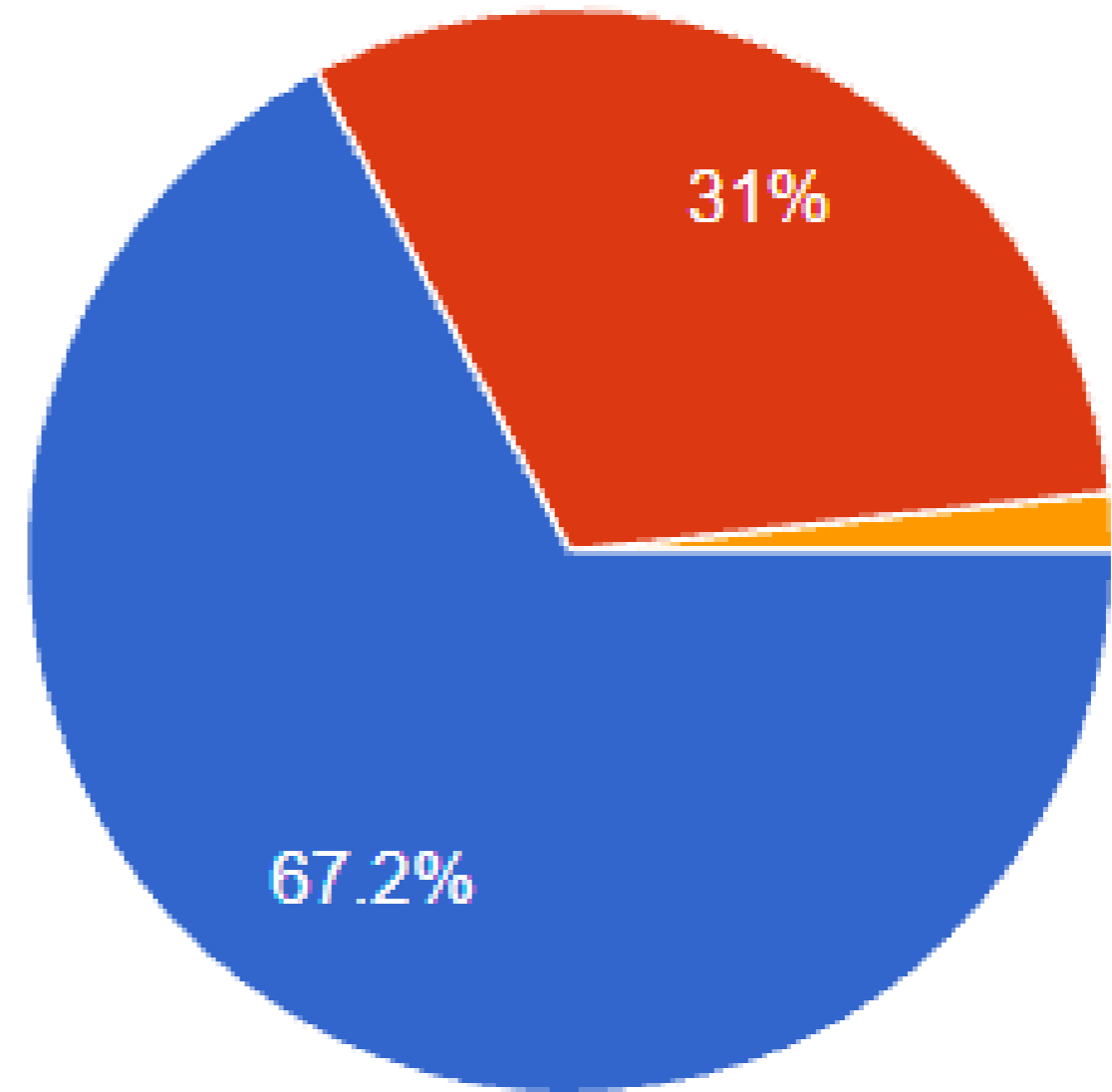



# QUESTION 9

DO YOU BELIEVE THAT YOUR DESIGNS CONNECT WITH THE “TRIPLE BOTTOM LINE” CO BENEFITS OF GSI? (I.E. ENVIRONMENTAL, SOCIAL AND FINANCIAL)

- Absolutely
- Sometimes
- Never
- I guess I don't really think about this

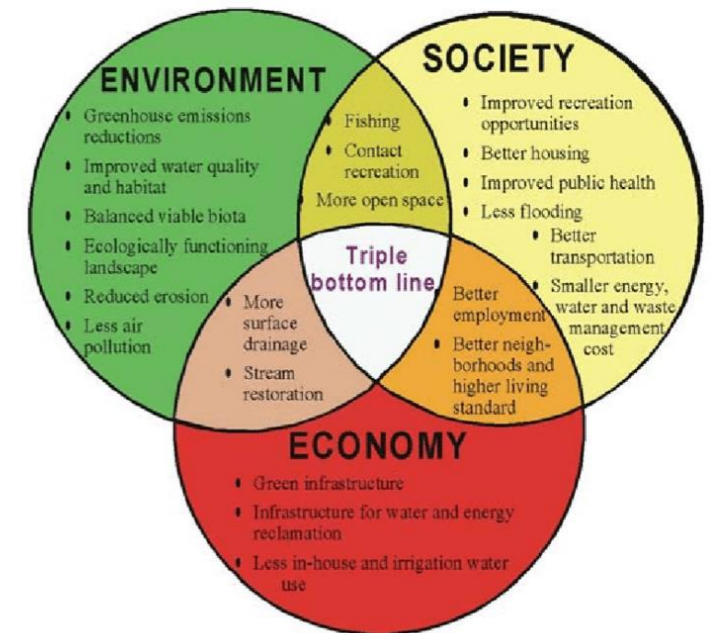
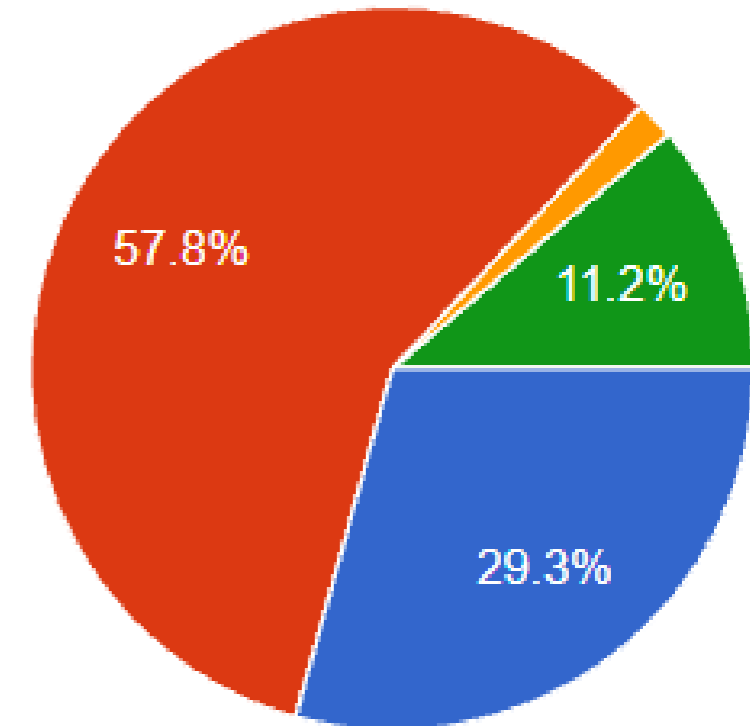

# QUESTION 11

DO YOU INCLUDE INNOVATIVE AND PROPRIETARY PRACTICES INTO YOUR DESIGN?

- Always
- Sometimes when traditional practices aren't feasible
- Never

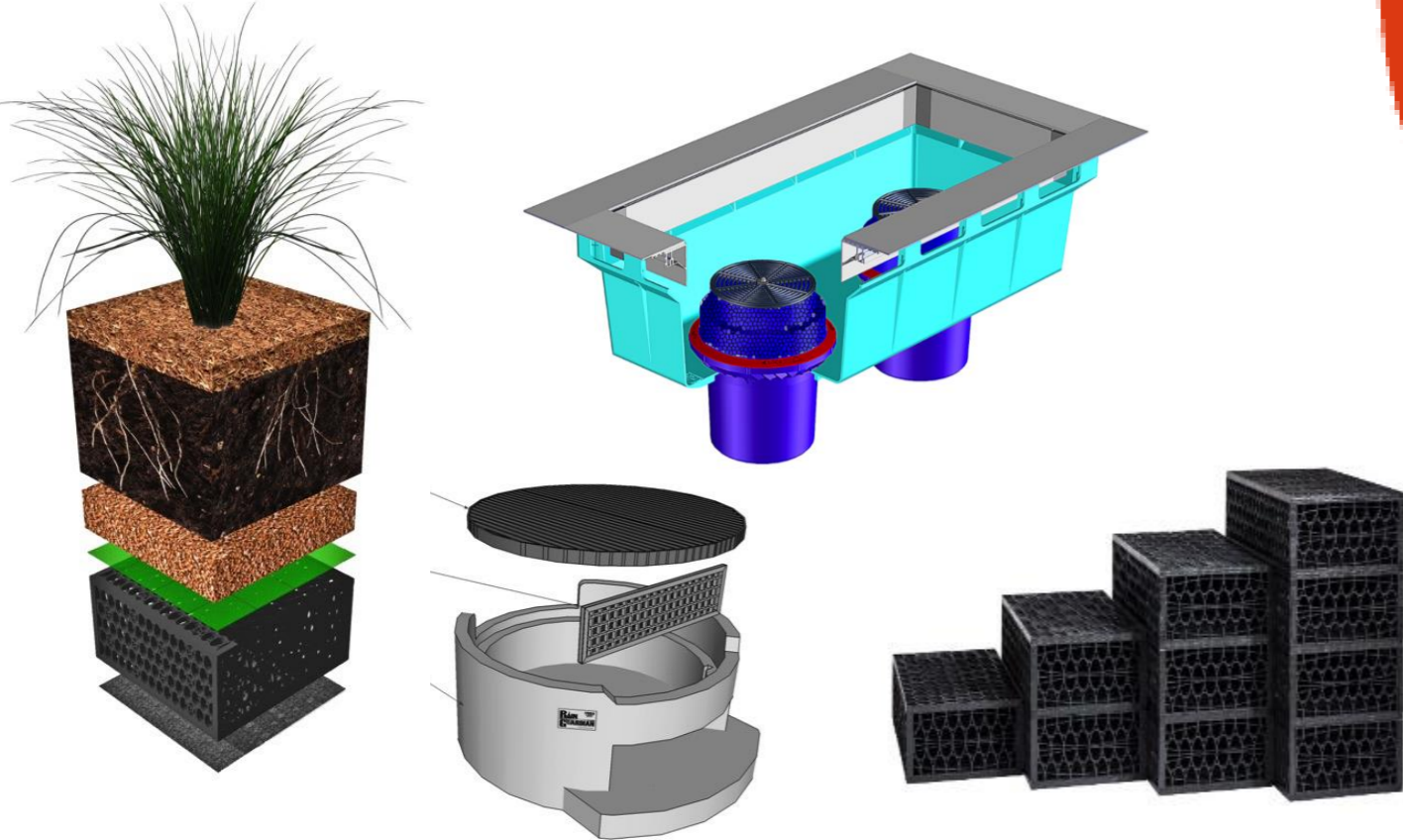
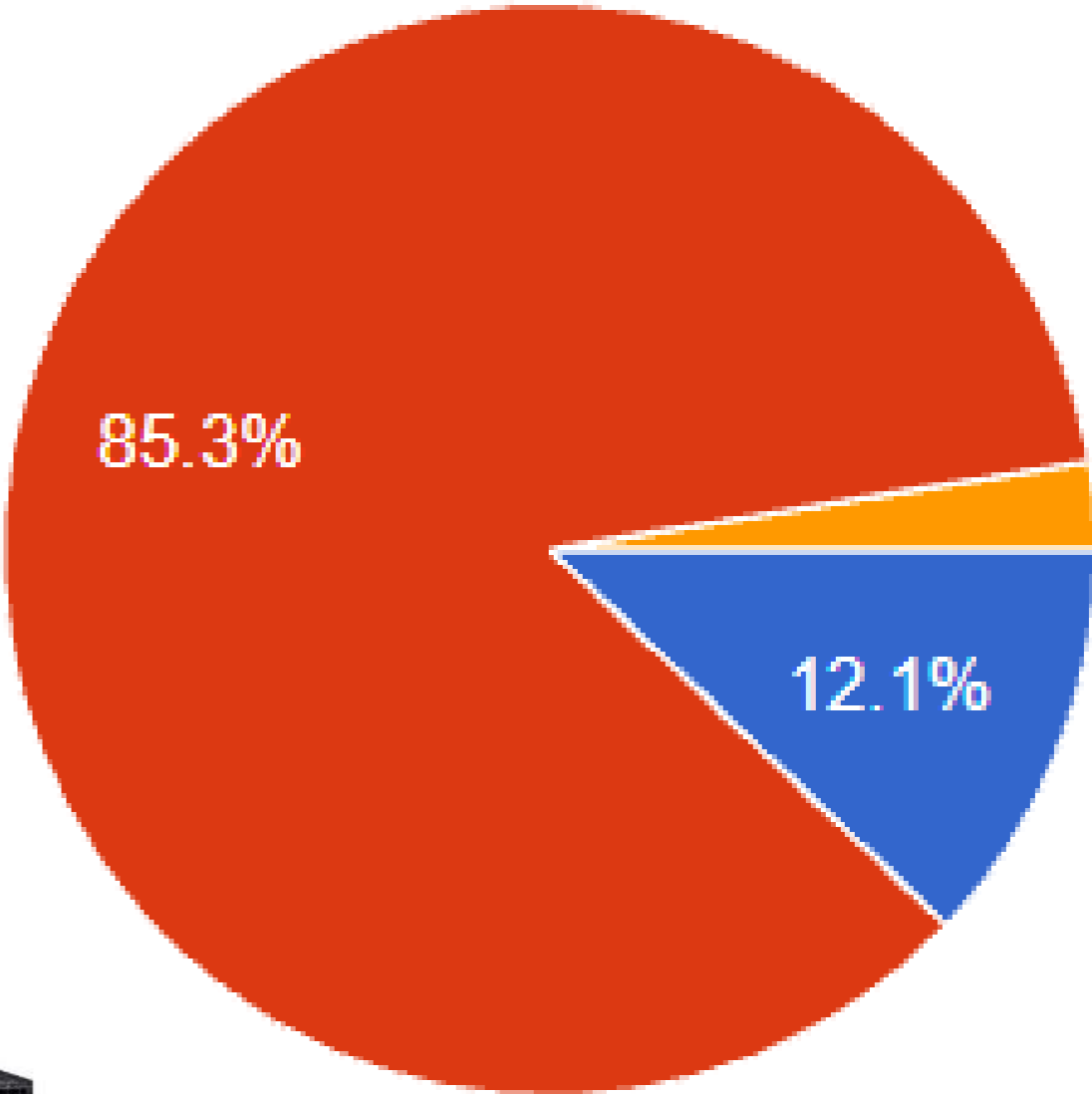

# QUESTION 12

DO YOU RESEARCH NEW DESIGN APPROACHES IN GSI OR STICK TO WHAT YOU HAVE USED IN THE PAST?

- Always look for new approaches to incorporate
- Sometimes look for new options but generally stick to what I've used before
- Never use new approaches, always use past details and designs

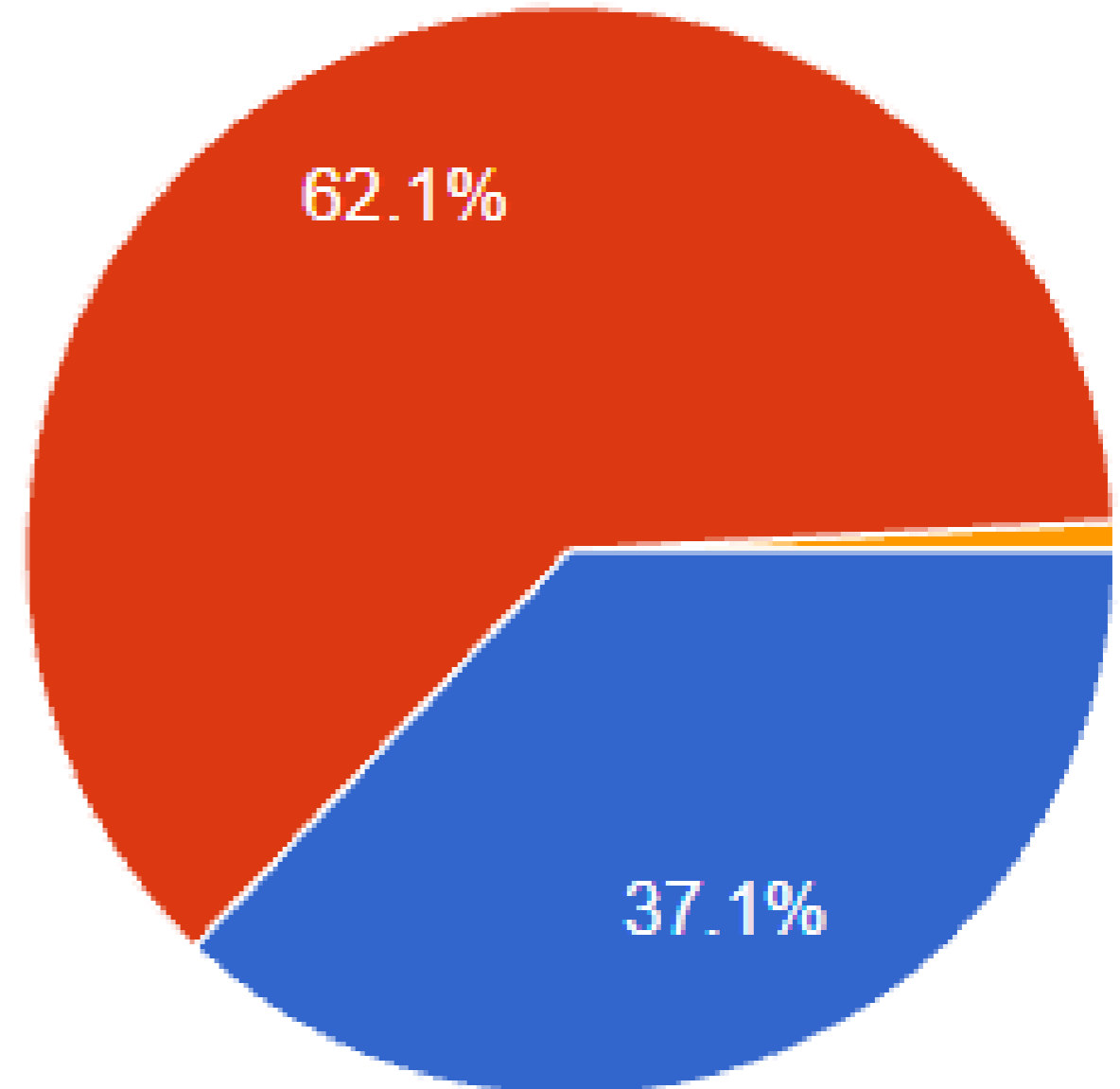

# QUESTION 13

DO THE CIVIL ENGINEER AND LANDSCAPE ARCHITECT COLLABORATE AND WORK TOGETHER IN YOUR DESIGNS?

- Always
- Sometimes
- Never

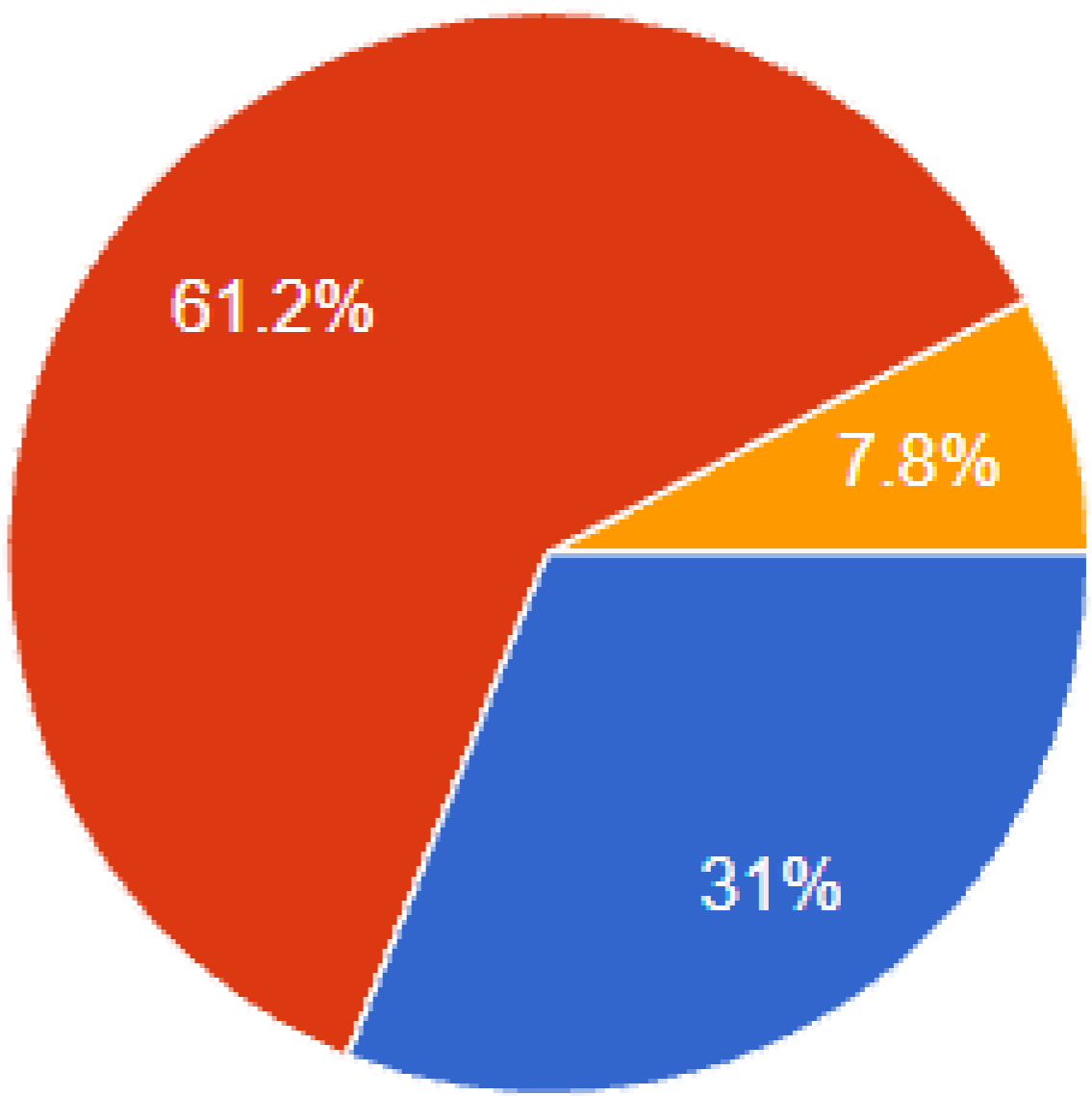

# QUESTION 19

IS PLANT SELECTION A PRIORITY IN YOUR DESIGN?

- Always
- Sometimes
- Never

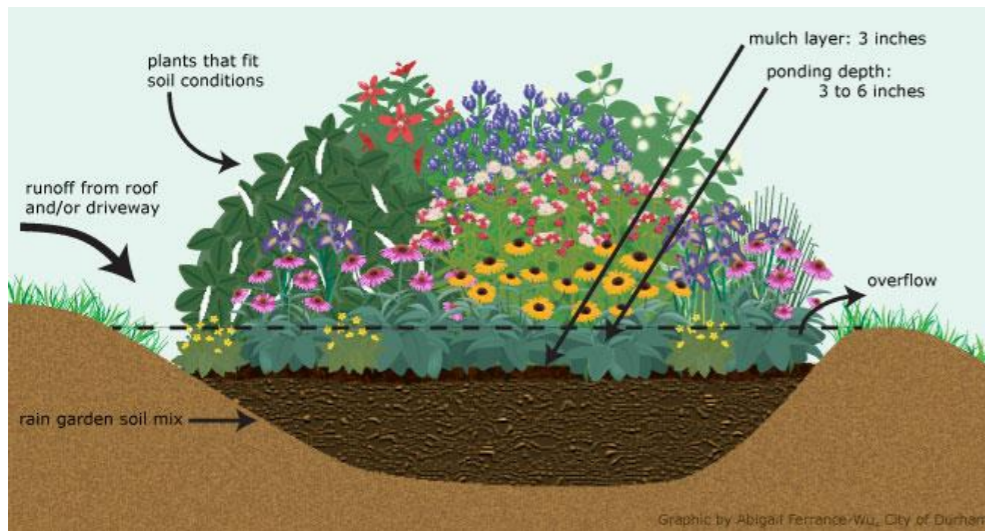
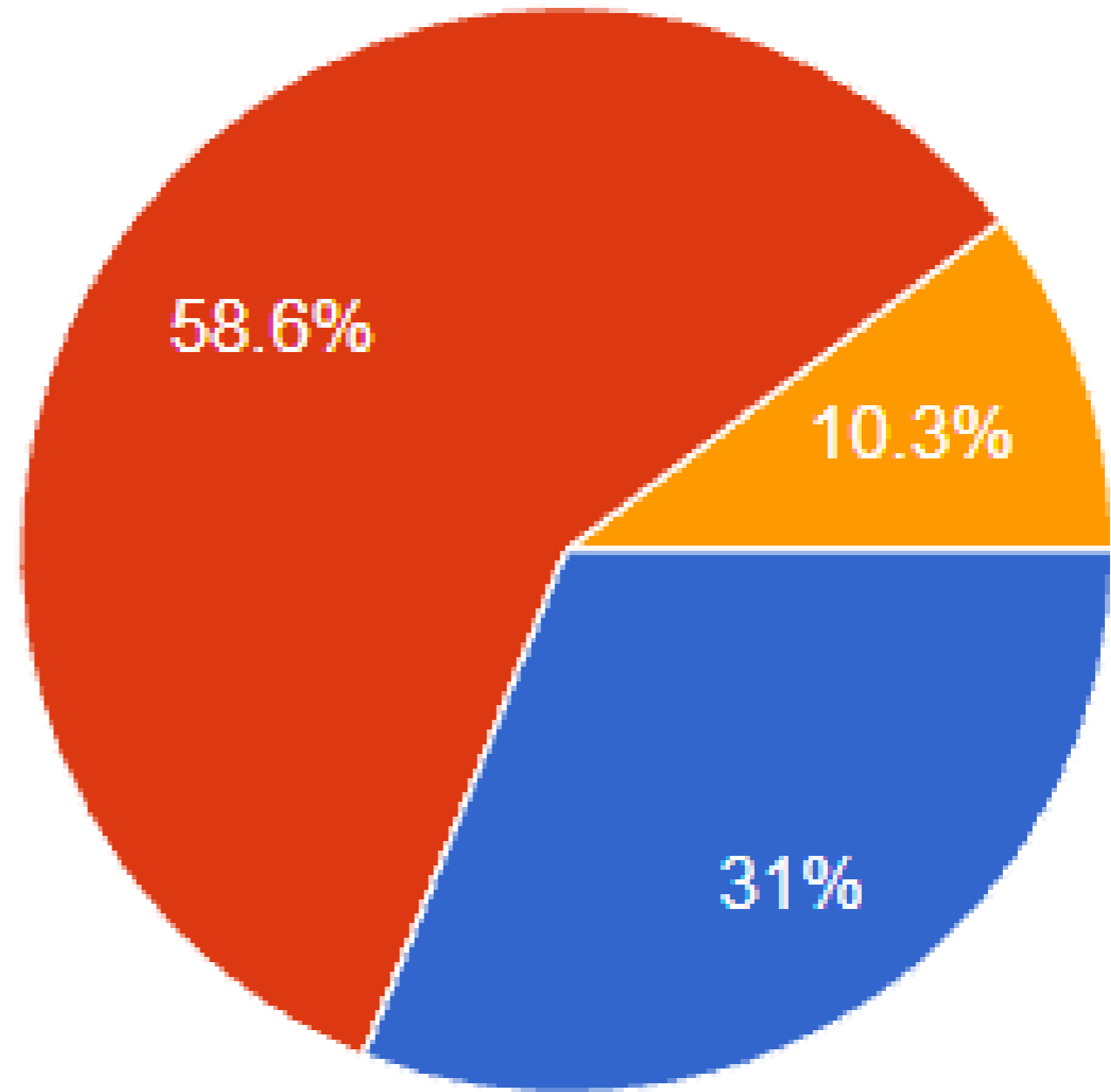

# QUESTION 14

IS PRETREATMENT INCLUDED IN ALL OF YOUR GSI PRACTICE DESIGNS?

- Always
- Most of the time
- Rarely
- Never

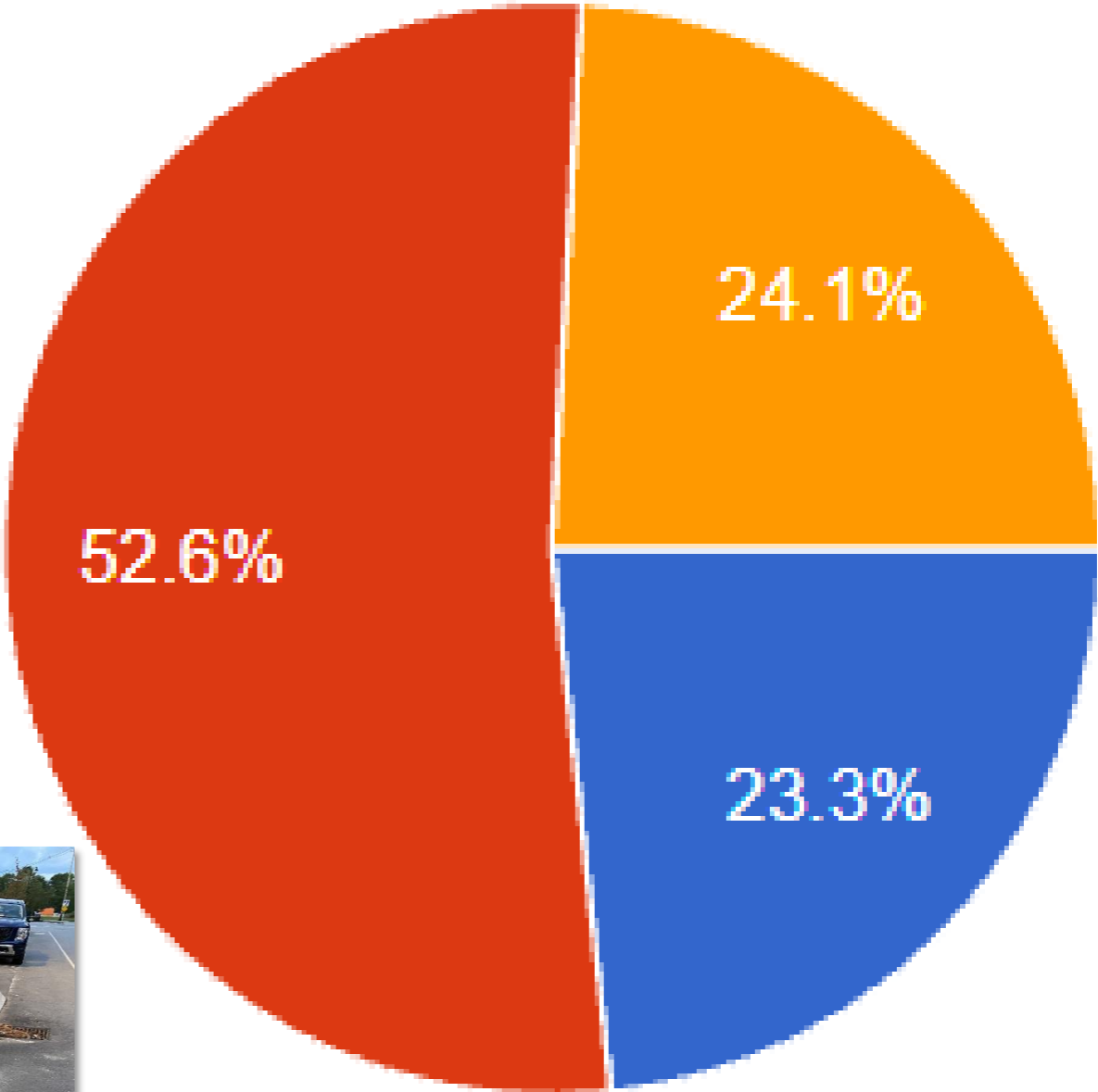

# QUESTION 16

DO YOU DESIGN WITH PERMEABLE SURFACES?

- Often
- Sometimes
- Never

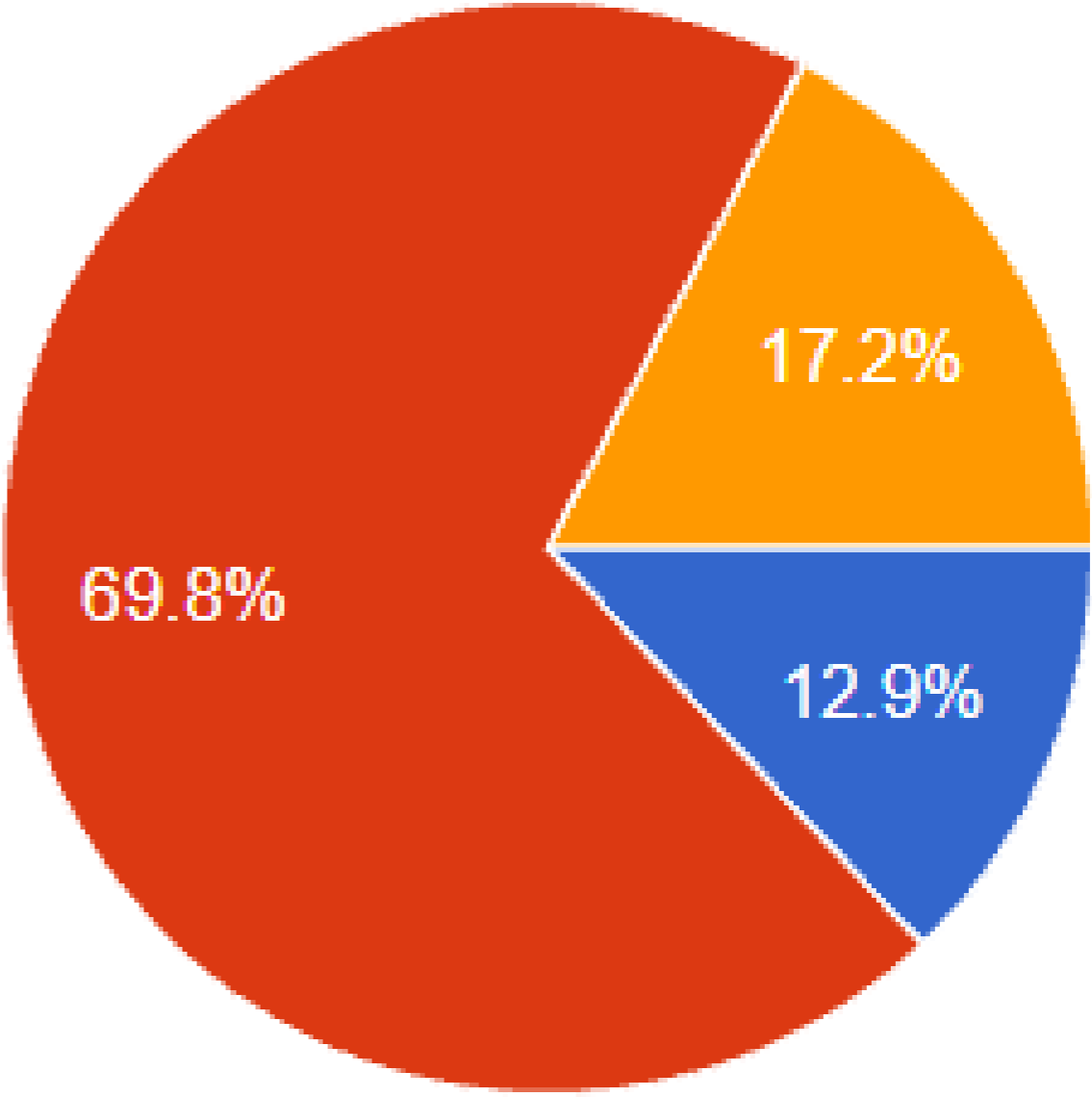

# QUESTION 17

IF YOU DESIGN WITH PERMEABLE SURFACES DO YOU MOSTLY DESIGN WITH:

- Porous Asphalt Pavement
- Porous Concrete Pavement
- Permeable Pavers
- Stone filled grid systems
- N/A - I don't design with permeable surfaces

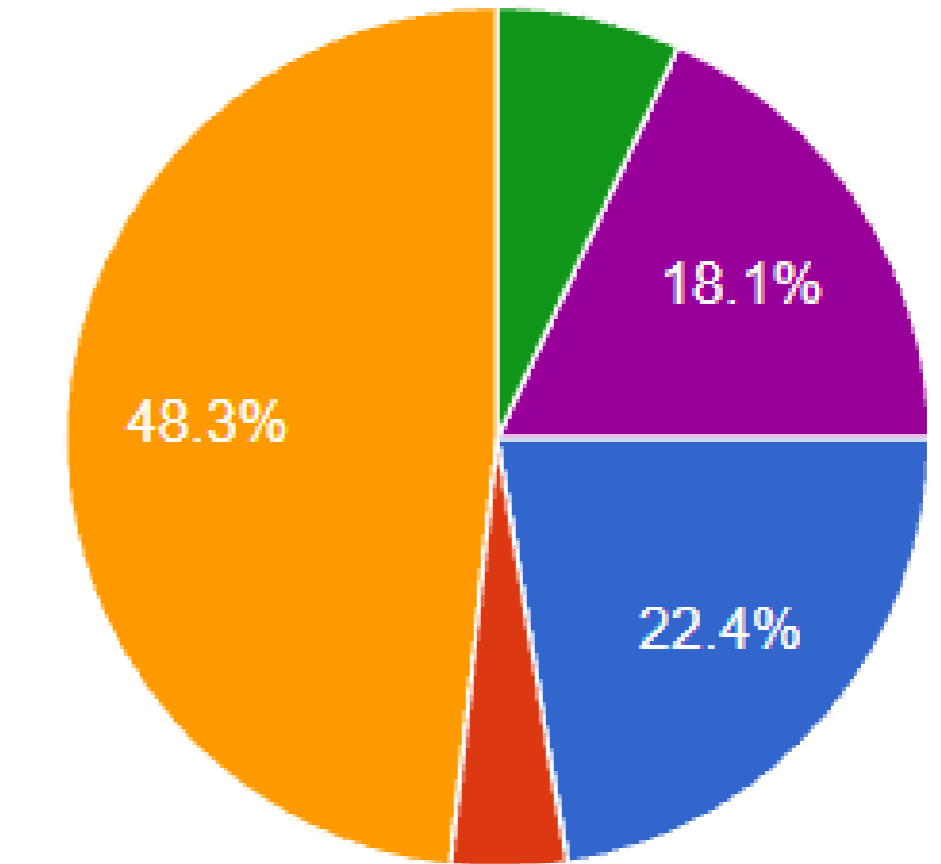



# QUESTION 18

IF YOU DON'T DESIGN WITH PERMEABLE SURFACES, WHAT IS THE PRIMARY REASON?

- Concerned about maintenance
- Never considered designing with them
- Concerned about performance during intense rain events
- The company I work for doesn't allow me to use them
- N/A - I use them all the time

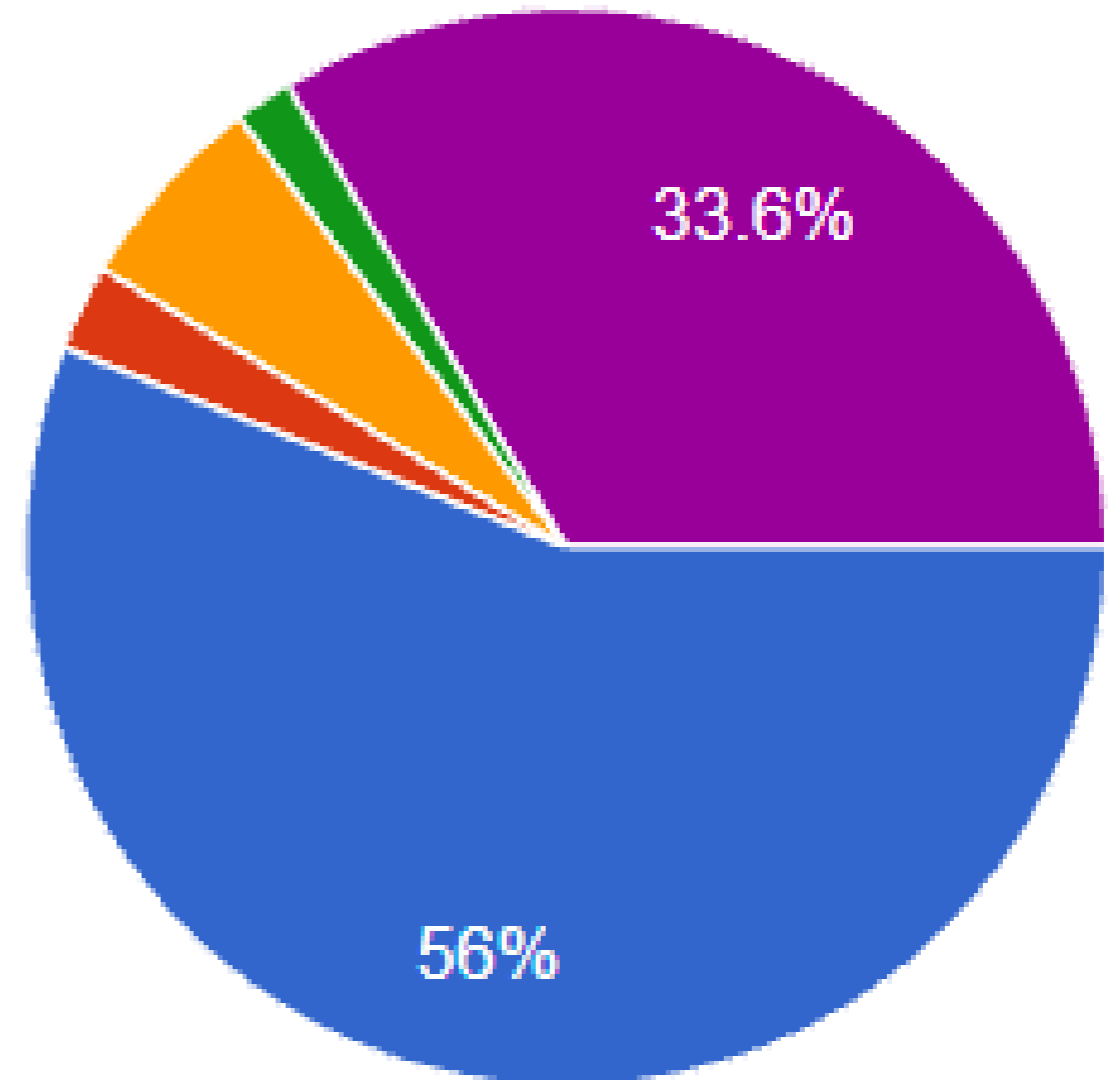

# QUESTION 22

ARE YOU INVOLVED IN CONSTRUCTION OVERSIGHT OF YOUR PROJECTS?

- Always
- Most of the time
- Rarely
- Never

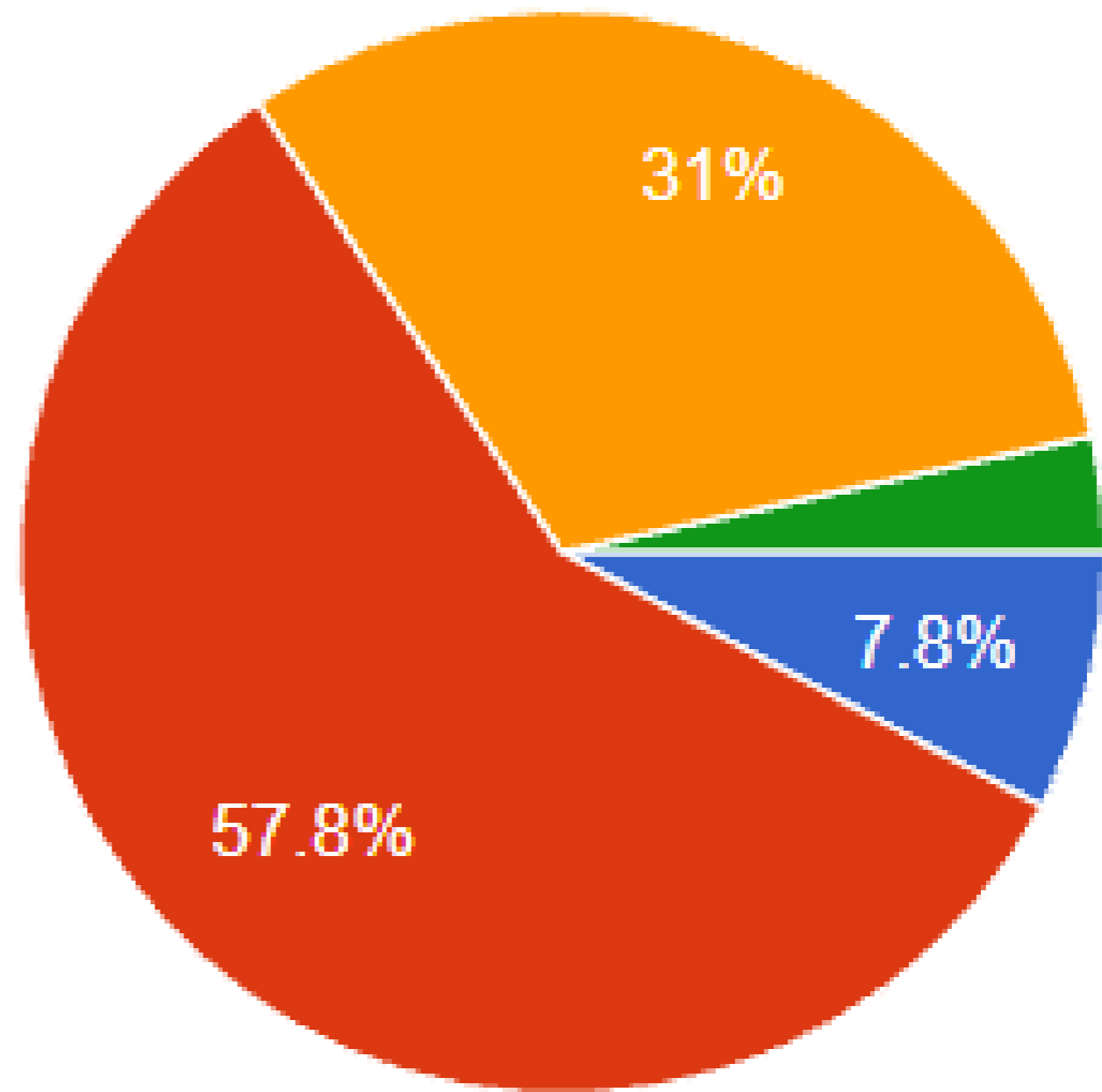

TECHNICAL  
STORMWATER MANAGEMENT

## PRE-CONSTRUCTION CHECKLIST

Project Name: \_\_\_\_\_  
Project City/State: \_\_\_\_\_ Reviewer Name: \_\_\_\_\_

The following points of discussion cover portions of the R-Tank® installation where questions arise and mistakes are commonly made. A thorough review of the R-Tank Installation Guide should be completed FIRST, and then the following items discussed in further detail:

- SUPPLY & REVIEW INSTALLATION GUIDE AND APPROVED SUBMITTAL**
- General Notes:** Contact ACF one week prior to installation for on-site installation support at NO COST.
- General Notes:** Discuss timing of system installation (cover materials with tarp per Spec Section 1.05 A if needed), as well as timing of activation and pre-treatment.
- General Notes:** Discuss importance of protecting R-Tank from construction traffic loads. Construction loads are typically the heaviest loads an R-Tank installation will ever experience, and many construction loads exceed the design loads of the system.
- Step #1:** Review proper assembly of unit for project:  LD  HD  SD  UD  XD  
Review questions / concerns about man hours, assembly tools, assembly area, staging units, etc.
- Step #2:** Excavation must exceed the actual R-Tank footprint by 2' around the entire system.
- Step #3:** Base MUST be smooth across entire excavation, even outside of R-Tank footprint. Hand raking is almost always needed to remove ruts, dips, and any other areas that are not level.
- Step #4:** Units simply butt together. If tying units together is desired, connecting the outside row should be adequate. Use zip ties or hog rings.
- Step #5:** End rows should be turned 90 degrees so that the large plate faces the perimeter of the excavation. As the units are roughly twice as long as they are wide, one parallel row can easily be converted into two perpendicular rows.
- Step #6:** If locations of Maintenance Ports are not identified on the plans, install them within 10' of all inlet/outlet pipes and roughly 50' on center. Don't forget to install anti-scour plate in the tank bottom and drill vent holes as specified.
- Step #7:** All pipe connections must penetrate the geotextile envelope and make direct contact with the R-Tank unit. Two hose clamps are included with each boot. One can be used inside the boot on the flaps of the "X" cut into the geotextile envelope, and the other on the neck of the boot.
- Step #8:** Side backfill must be placed evenly around the units to prevent shoving/tilting of the units. ALWAYS use vibratory compaction of the side backfill to help consolidate BOTH the tanks and the backfill materials.
- Step #9:** Always use light-weight track machinery to push backfill materials over the top of the system. Compact material with walk-behind equipment or max 6 ton roller. Failure to do this step properly accounts for 90% of all installation errors!
- Step #10:** Geogrid should extend at least 5' beyond the R-Tank footprint. If magnetic locating tape is required, this is a good place to install it.
- STEP #12:** Use of safety fence, caution tape, or some form of barricade surrounding the installation is required until completion of the project (not just during the installation of the R-Tank).

Reviewed With: \_\_\_\_\_ Company Name: \_\_\_\_\_  
Printed Name: \_\_\_\_\_ Date: \_\_\_\_\_



# QUESTION 23

ARE THE SYSTEMS YOU DESIGN PROTECTED DURING CONSTRUCTION?

- Always
- Most of the time
- Rarely
- Never

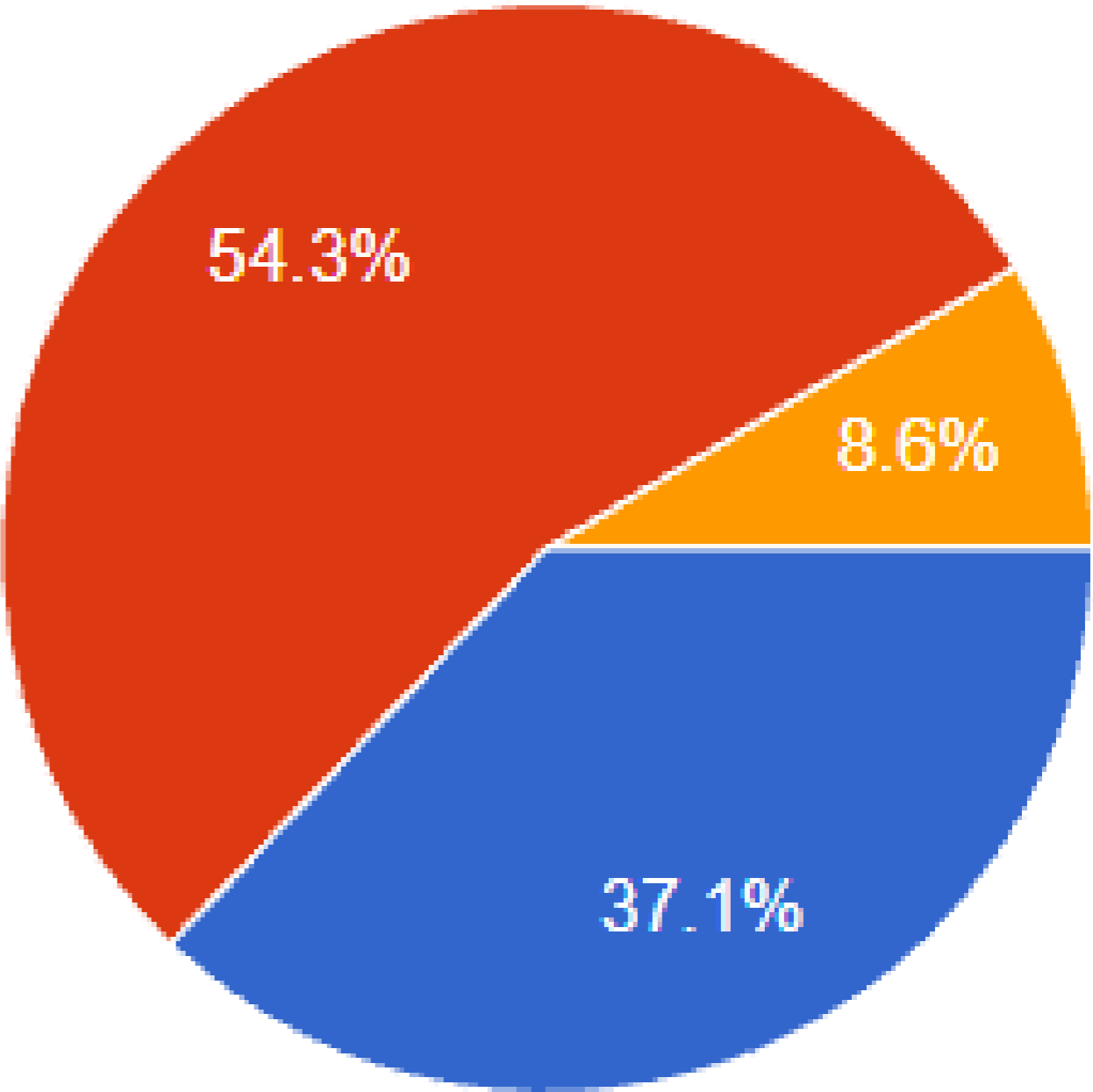

# QUESTION 26

AFTER THE PROJECT IS COMPLETE, DO YOU MEET WITH YOUR DESIGN TEAM FOR PROJECT "FORENSICS" TO DISCUSS WHAT MODIFICATIONS NEED TO BE MADE FOR FUTURE PROJECTS?

- Always
- Sometimes
- Never - need to move to the the next one no time to pause

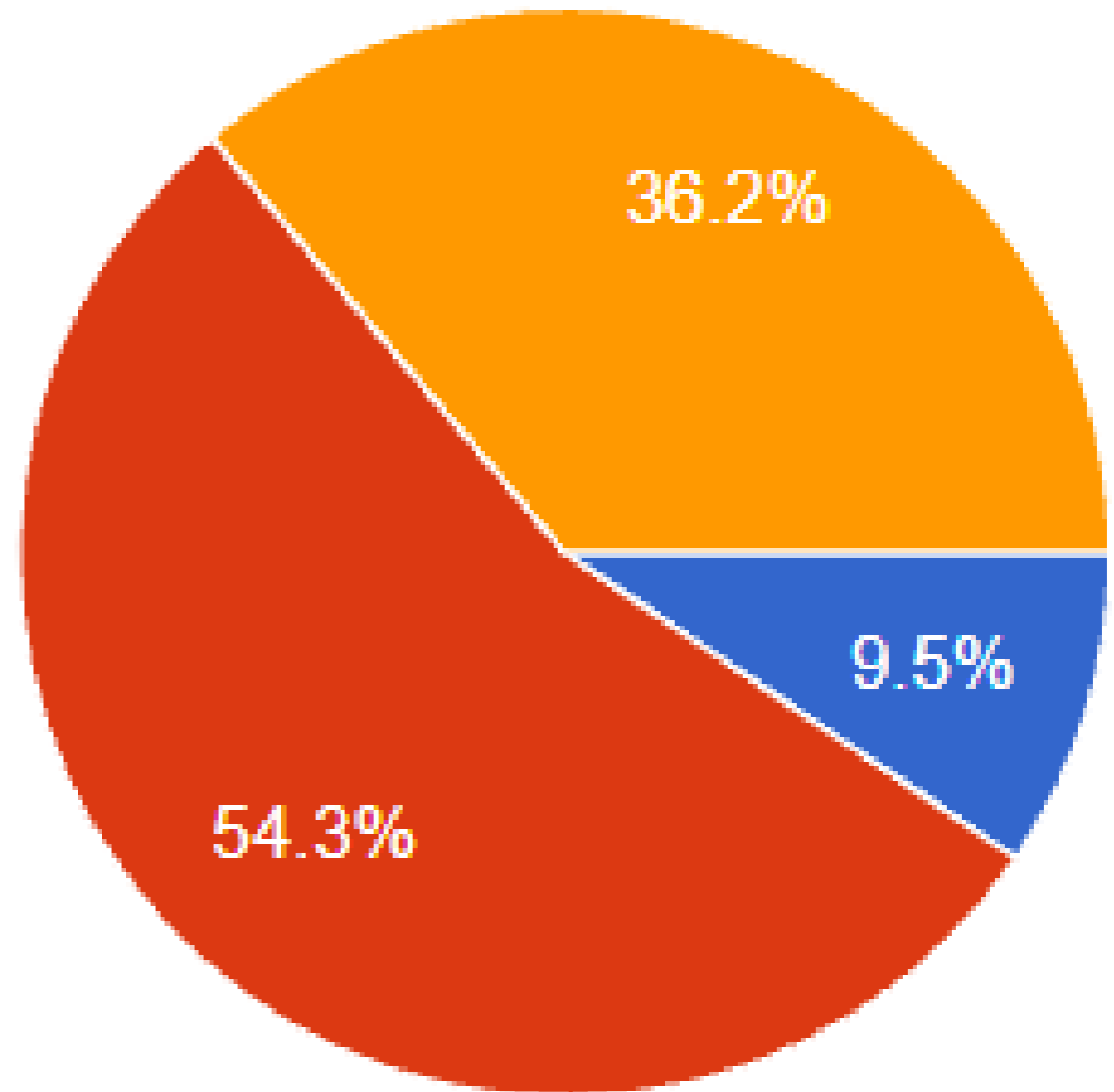

# QUESTION 27

ARE THE SYSTEMS YOU DESIGN GENERALLY MAINTAINED TO THE LEVEL YOU ARE HOPING FOR?

- Always
- Most of the time
- Rarely
- Never

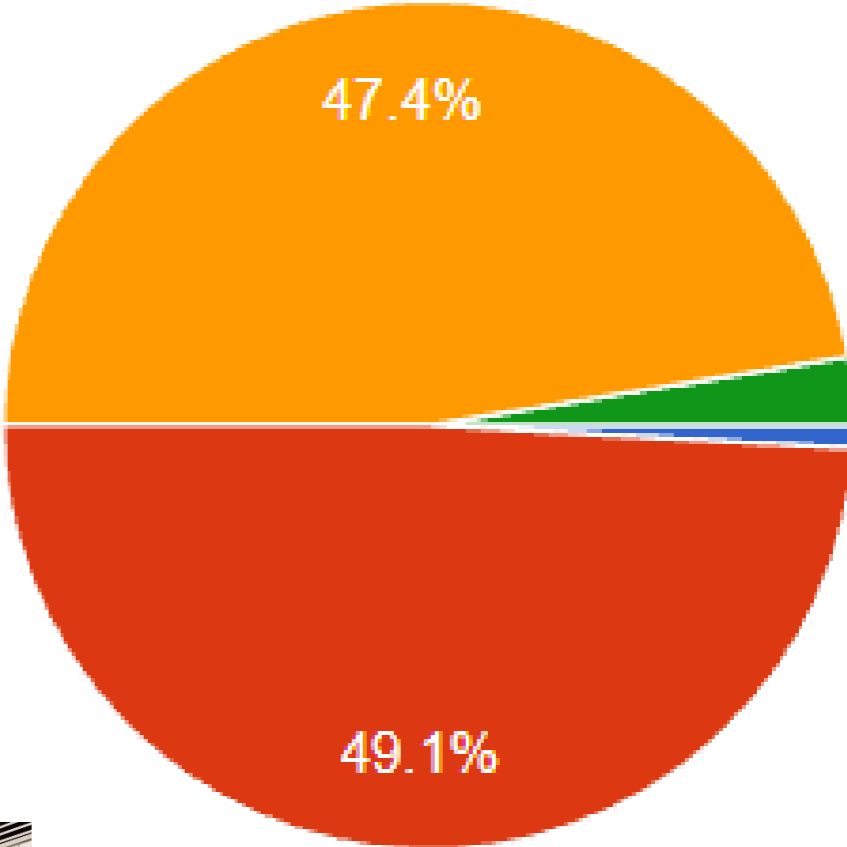

TWO VERY DISTINCT GROUPS – ONES THAT MAINTAIN AND ONES THAT DONT

# QUESTION 28

HOW OFTEN DO YOU DISCUSS MAINTENANCE WITH YOUR CLIENT?

- Always
- Sometimes
- Never

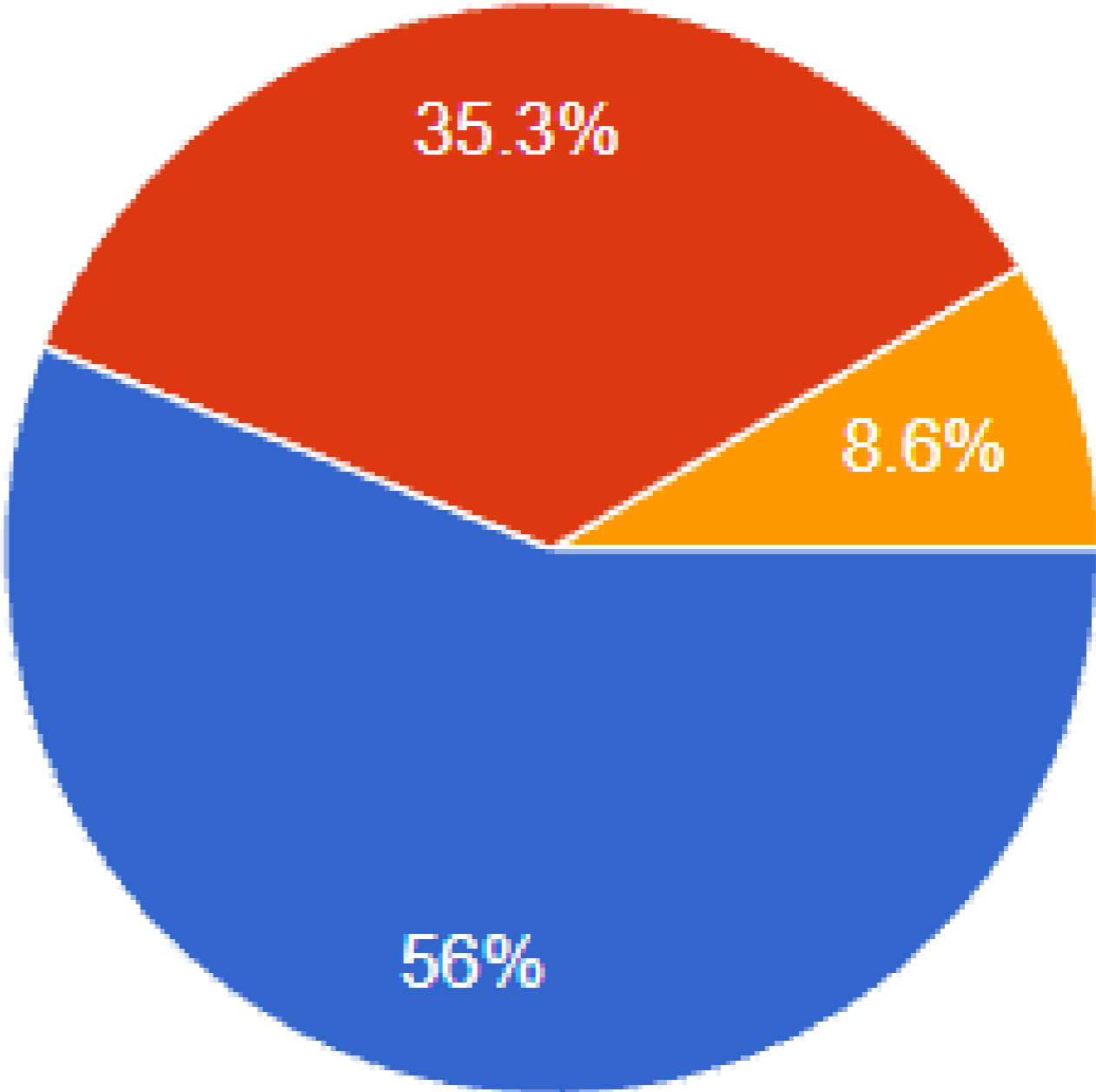

# QUESTION 29

DO YOUR CLIENTS BUDGET FOR ONGOING MAINTENANCE OF GSI PROJECTS?

- Always
- Sometimes
- Never

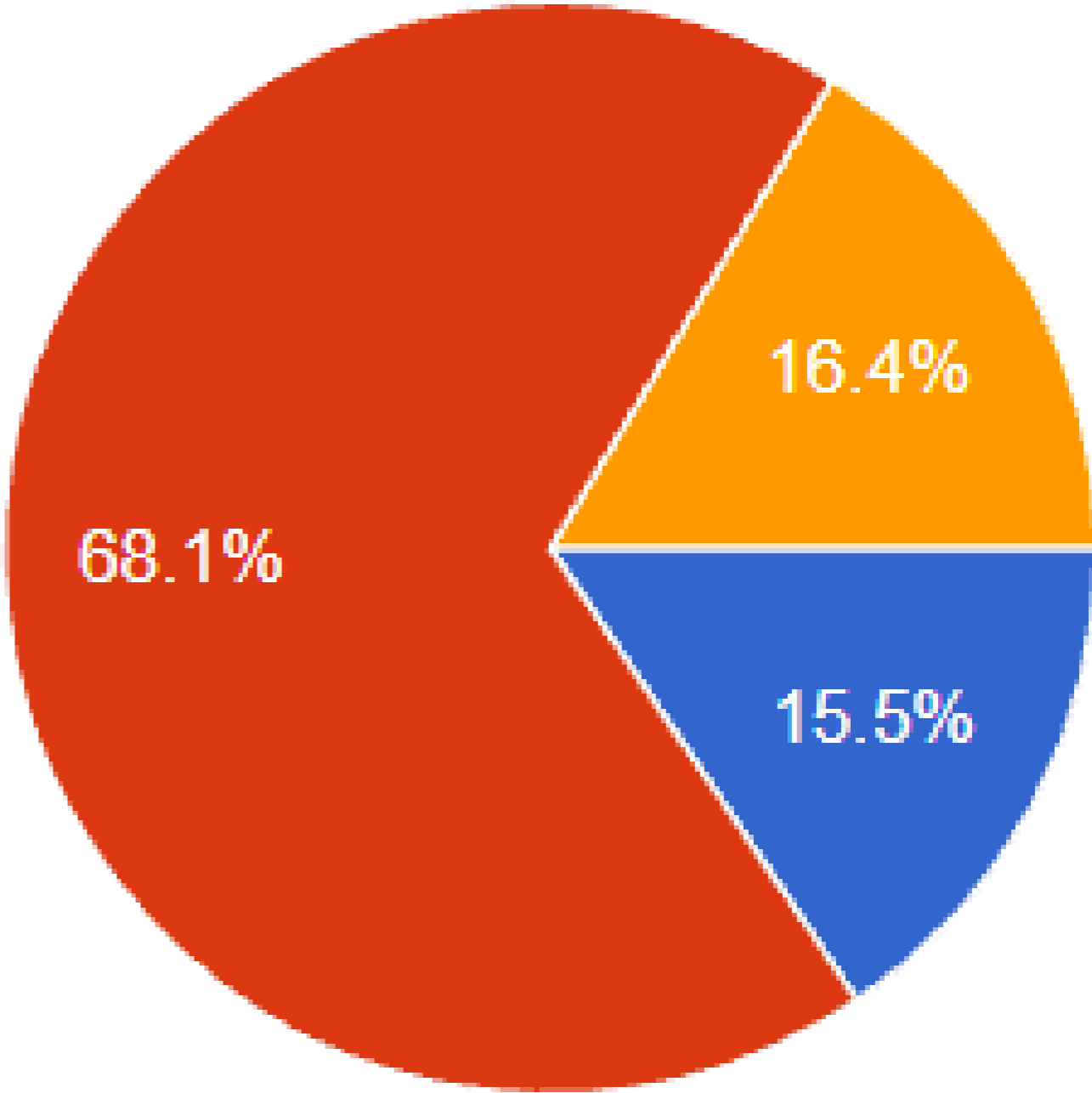

# BONUS GENERAL QUESTION

WHAT DO YOU SEE AS THE BIGGEST CHALLENGE FACING GSI PROJECTS AND PROGRAMS TODAY?





# TAKE HOME MESSAGE

- We need to be thinking about ways to better collaborate from design all the way through to construction and post installation maintenance.
  - We need to pause and take what we are learning in the field and modify / adapt / revise our approaches for more sustainable outcomes. Pretreatment is a big one!
  - We need to consider using new approaches and solutions to achieve goals.
  - We need to consider ways to leverage the triple bottom line co-benefits of GSI
  - We need to communicate maintenance obligations more clearly and make sure that maintenance is happening.
  - We need to make sure we are budgeting for maintenance.
  - We need to work together to overcome the biggest challenges facing GSI – Cost and maintenance
-

# Thank you!!



Rob: 207-272-4431 | Ben: 571-266-2342



rob.woodman@ferguson.com | ben.miller@ferguson.com



12500 Jefferson Ave  
Newport News VA