

# Global Solutions



## Cla-Val Statement of Qualifications





# Table of Contents

<b>Company Overview and Commitments to Our Customers</b>	<b>1</b>
<b>Corporate Social Responsibility</b>	<b>2</b>
<b>Inventor &amp; Producer of the First Hytrol</b>	<b>3</b>
<b>Onsite Foundries</b>	<b>4</b>
<b>Global Manufacturing Facilities Overview</b>	<b>5</b>
<b>Product Range</b>	<b>6</b>
<b>Research and Development</b>	<b>6</b>
<b>Training Capabilities and Facilities</b>	<b>6</b>
<b>Online Resources</b>	<b>7</b>
<b>Approvals &amp; Certifications</b>	<b>8</b>
<b>Waterworks Industry Overview</b>	<b>9</b>
<b>Industrial Facility Overview</b>	<b>10</b>
<b>Fire Protection Industry Overview</b>	<b>11</b>
<b>Aviation Fueling Industry Overview</b>	<b>12</b>
<b>Marine Industry Overview</b>	<b>13</b>
<b>Quality Control Program</b>	<b>14</b>
<b>Environmental Health and Safety Program</b>	<b>14</b>
<b>Technical Documentation</b>	<b>15</b>
<b>Technical, Factory and Sales Contact Information</b>	<b>Back Cover</b>

# Global Leadership In Automatic Control Valve Design and Manufacturing

## Company Overview

Cla-Val is a leading manufacturer of automatic control valves, serving waterworks, industrial, fire protection, aviation fueling and marine customers in more than 100 countries worldwide. Founded in 1936, our commitment to excellence and continuous improvement shows in each valve we produce and in the many new products we introduce to the marketplace each year.

Cla-Val is a global company with headquarters and a twenty-acre manufacturing/foundry complex in Costa Mesa, California, in addition to production facilities in Canada, Switzerland, France, the United Kingdom and New Zealand.



Cla-Val's long history of manufacturing and technical expertise also enables us to provide the industry's most comprehensive program of hands-on, personalized product training at our in-house training facilities in the US, Canada, Switzerland, the UK, France and New Zealand.

Cla-Val Automatic Control Valves are known for their exceptional quality and superior performance. The company is also recognized as a leader in the development of innovative technologies, specifically related to electronic products that help to conserve water and energy. Cla-Val's customer focus and commitment to excellent customer service is second to none.

Our company website at [www.cla-val.com](http://www.cla-val.com) offers a comprehensive overview of our extensive product line and field service capabilities as well as access to hundreds of technical documents.



## Commitment to Our Customers

- Cla-Val is committed to providing the highest quality automatic control valves at fair prices and deliveries in line with our customers' requirements.
- Cla-Val is committed to using ethical business practices with our customers, vendors, employees and other people with whom we come into contact.
- Cla-Val is committed to employing the best possible resources to provide our customers with ongoing improvements, advances and new concepts in our product offering.
- Cla-Val is committed to employing environmentally appropriate technology in all of our business activities. That commitment is illustrated by investments in our foundry and manufacturing facilities that enable us to comply with strict environmental requirements. Recent upgrades include thermal sand reclamation machinery, air filtration systems and high-efficiency furnaces.

## Our Promise

As a global leader in the manufacture and design of automatic control valves, Cla-Val prides itself in being a socially responsible company in all areas of our business. We strive to make a positive impact in our communities and conduct business in accordance with the following policies:

- **Global Conflict Minerals Policy**

Cla-Val is committed to conducting business with a high degree of integrity and to conduct our business in a responsible manner. We support ending the violence and human rights violations in the mining of certain minerals in “Conflict Regions” and fully enforce Section 1502 of the US Dodd-Frank Wall Street Reform and Consumer Protection Act of 2010 (the “Dodd-Frank Act”).

- **Environmental Policy**

Cla-Val Company is committed to compliance with all applicable environmental and safety laws and to the protection of our employees. Beyond regulatory compliance, Cla-Val seeks to be a good steward of the Environment in which we conduct our business. Cla-Val also seeks to invest and protect its most valuable assets, each and every one of its employees.

- **Corporate Stewardship**

Cla-Val’s ownership, management, and employees believe very strongly in being responsible stewards of the company’s resources. Whether these resources be financial, environmental, or the personnel that comprise the company, Cla-Val seeks to do the very best with what we have. It is a privilege of the entire organization to give back to the communities in which we serve. By participating in local, national, and international causes, Cla-Val is able to reinvest its profits into causes supported by the organization.

- **Supplier Code of Conduct**

Cla-Val is committed to the highest ethical and legal standards in the conduct of its business. We are committed to comply with all applicable laws and regulations and to the upholding of human rights, as well as the protection of the environment. These commitments expand beyond our own operations, and extend into all aspects of our supply chain. As such, Cla-Val expects our suppliers and any sub-contracted suppliers to share these same commitments and values.

- **California Transparency in Supply Chains Act**

Cla-Val is committed to ensuring that our supply chain reflects our values and respect for human rights. As a part of our standard terms and conditions as well as the principles outlined in our Supplier Code of Conduct, we require our suppliers to comply with all applicable laws and to not engage in or support the use of child, forced, or involuntary labor.



**For a complete version of the policies referenced above, please visit:**

<http://www.cla-val.com/corporate-responsibility-i-63-l-en.html>

# Cla-Val Statement of Qualifications: A History of Excellence

## Inventor and Producer of the Hytrol Control Valve

### In the Beginning...

In the mid 1930s, the founder of Cla-Val, Donald G. Griswold designed the first hydraulic automatic control valve which was later dubbed the "Hytrol".

The 1940 patent for the Hytrol valve was the first of many new and innovative products Cla-Val would bring to the marketplace over the ensuing years.

The tradition of being Inventors, Innovators and Standard Bearers for Excellence lives on at Cla-Val as we celebrate our 75th year in business.

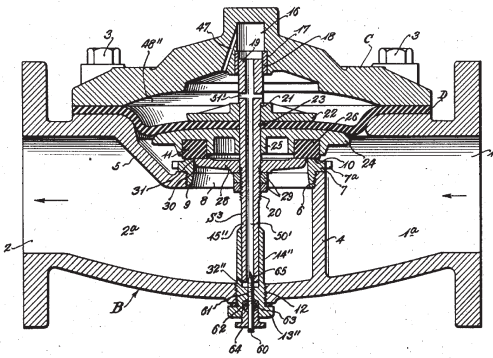

Aug. 31, 1943. D. G. GRISWOLD 2,328,009  
Original Filed May 1, 1940

## One of the world's first automatic control valve manufacturers



# Innovation since 1936

# Cla-Val Statement of Qualifications: Onsite Foundries

## Onsite Foundries

**Soundcast Company – Sand casting foundry**  
**Griswold Castings – Investment foundry, lost wax process**

By having two on-site foundries, Cla-Val is able to provide castings in over 55 different alloys, making our product offering one of the most extensive in the valve industry. It also allows us to respond more quickly to our customers' unique requirements. A small sample of the many materials our foundries produce include the following alloys:

- Ductile Iron
- Cast Steel
- Stainless Steel
- Monel
- Nickel Aluminum Bronze
- Naval Bronze
- Super Austenitic Stainless Steel
- Super Duplex Stainless Steel
- Titanium



Industrie Service



***Soundcast delivers quality.***



# Cla-Val Statement of Qualifications: Manufacturing Overview

## Global Manufacturing Facilities Overview

State-of-the art manufacturing equipment:

- Multiple Mazak Multi-Task Milling & Turning; CNC Lathe & Milling machines
- Many more manual machine cells including Vertical Turret Lathes

Large inventory of products on the shelf and ready to ship to meet customers' immediate needs



Computerized Multi-Task Machining



"E-Machine" - The latest in CNC Machining Equipment



Pilot Assembly - Adding the finishing touches



Final Assembly and Inspection



Maintaining a broad range of sizes and configurations to meet our customers' immediate requirements



Committed to keeping an inventory of high demand products for critical applications



# Cla-Val Statement of Qualifications, Product Range

## Product Range

Cla-Val offers an extensive range of products from basic hydraulic valves to SCADA compatible electronic control valves to perform the following functions in waterworks, water savings, industrial, fire protection, marine and aviation fueling applications.

Pressure Reducing

Pressure Relief

Pressure Management

Pressure Increasing

Cavitation Prevention

Surge Control

Electronic Flow Metering

Pump Control

Rate of Flow/Flow Limiting

Level Control

Tank Filling

Blending

Flushing

Reclaimed Water

Fire Suppression Deluge

Air Release

Vacuum Breaking

Flow Reversal Prevention

Fueling High-Level Shut-Off

Fueling Back Pressure Control

Contamination Monitoring

## *Built to last a lifetime*

## Size Range

from the smallest: 1/2-inch



To the largest: 48-inches



...and everything in between



# Cla-Val Statement of Qualifications: Research & Development • Training • Online Resources

## A Commitment to Research and Development: Cla-Val Product Innovations Set the Standard

Cla-Val automatic control valves reflect the lessons learned through more than seventy-five years of real-world experience in the industries we serve. This, coupled with our aggressive research and development programs, has resulted in the design and production of technologically advanced products that meet the challenges of increasingly complex and diverse applications. Our commitment to product innovation is embodied by our in-house R&D teams and state-of-the-art R&D labs in the US and Switzerland.



Cla-Val USA R & D Laboratory

## Training Capabilities and Facilities

Cla-Val offers personalized technical assistance, maintenance support, and end-user training programs. Comprehensive engineering, service and application seminars are offered at each of our worldwide locations, including our new facility in New Zealand as well as at customer facilities. This, in turn, helps our customers to achieve optimal performance of Cla-Val products during start-up, after installation and through decades of reliable trouble-free service.



Cla-Val Europe R & D Laboratory



Cla-Val Canada Training Facility



Cla-Val USA Training Facility



Cla-Val Europe Training Facility

## Global Company Websites: USA • Europe • New Zealand The Definitive Online Resource for Automatic Control Valves

In addition to our experienced staff of Engineers and Product Specialists, Cla-Val's websites located at [www.cla-val.com](http://www.cla-val.com) (USA), [www.cla-val.ch](http://www.cla-val.ch) (Europe) and [www.cla-valpacific.com](http://www.cla-valpacific.com) provide round-the-clock technical assistance via access to hundreds of technical documents.

[www.cla-val.com](http://www.cla-val.com) • [www.cla-val.ch](http://www.cla-val.ch)  
[www.cla-valpacific.com](http://www.cla-valpacific.com)



# Cla-Val Statement of Qualifications: Approvals and Certifications

## Approvals and Certifications

Cla-Val's waterworks and fire protection products meet all applicable standards and specifications prescribed by industry organizations such as AWWA, FDA, NSF, UL, and FM International. Along with ISO 9001 certifications for our production facilities in the US, Switzerland and the UK, and ISO 9002 for our manufacturing facility in Canada, Cla-Val also currently holds many other certifications, listings and approvals in North America and around the world.



- International Organization for Standardization (ISO)
- NSF International
- American Society of Sanitary Engineers (ASSE)
- Canadian Standards Association (CSA)
- Water Regulations Advisory Scheme (WRAS)
- Swiss Gas and Water Industry Association (SVWG)
- Austrian Association for Gas and Water Industries (OVGW)
- International Organization for Standardization (ISO)
- NYC Material and Equipment Acceptance Division (MEA)
- Public Utilities Board Singapore (PUB)
- Technical Standards & Safety Authority (TSSA)
- Underwriter's Laboratory (UL)
- Underwriter's Laboratory Canada (ULC)
- FM Global Technologies (FM)
- Department of the Navy
- Soundcast Foundry: TUV Approval
- American Petroleum Institute
- ATEX



## NSF/ANSI STANDARD 61 Drinking Water System Components - Health Effects

Cla-Val Hytrol Valves in sizes from 1-1/4-inches through 36-inches meet the requirements set forth in NSF/ANSI Standard 61.



## American Recovery and Reinvestment Act of 2009

Cla-Val Automatic Control Valves meet the "Buy American" Provisions of the ARRA.



## Lead Limits for Products used in Waterworks Systems

Cla-Val Automatic Control Valves comply with the national lead free mandate "**Reduction of Lead in Drinking Water Act**" that dictates allowable lead levels in products used in water utility distribution piping systems.



# Cla-Val Statement of Qualifications: Waterworks Industry

## Cla-Val Waterworks Industry Experience and Capabilities



Cla-Val's automatic control valves are specifically designed to meet the requirements of water utility systems, greatly improving supply and distribution system efficiency. Our valves perform with precision and accuracy to provide exact control of pressure, flow, level, surge and pump control. Cla-Val electronic interface control valves combine the efficiency of hydraulic control with advanced technology electronics to provide the optimum SCADA remote control solution. Our commitment to developing solutions for our customers' operational challenges is demonstrated by the many product innovations we introduce to the waterworks market every year including the X144 Electronic Flow Meter, 33 Series Electronic Pilot Controls and X143 Series Power Generators.

Areas of expertise include a wide range of control valve applications for:

- Waterworks Distribution Systems
- SCADA Control
- Water Treatment Plants
- Reclaimed Water Systems

Visit [www.cla-val.com](http://www.cla-val.com) and click on the product links to see the wide variety of applications for Cla-Val Automatic Control Valves



Pressure Reducing Station in a municipal water distribution system



PRV Vault with integral power generator, electronic pilot control and e-FlowMeter



Remote SCADA control



Modulating Level Control with Metering



30-Inch Pump Control Valves



Multiple Valves in Industrial Application

# Cla-Val Statement of Qualifications: Industrial Facilities

## Cla-Val Industrial Experience and Capabilities

Cla-Val has been in the control valve business for nearly 80 years. The Engineering expertise we have developed along the way has enabled us to design thousands of valve configurations for both standard and complex applications. Our fully staffed, in-house Engineering team, combined with extensive industry knowledge enables us to develop solutions for just about any industrial fluid control application you can think of.

Since the first Cla-Val Automatic Control Valve was produced in 1936, we have manufactured the best quality control valves available. We utilize the latest in manufacturing technology to ensure that each valve we produce is precisely machined to meet the exacting standards of the industrial marketplace.

One of Cla-Val's greatest strength is the ability to produce valves in **more than 50 different metals** poured in two on-site foundries located at our 20-acre facility in Southern California.

Each valve is tested and inspected before leaving the factory in accordance with the Cla-Val Quality Control Program and ISO 9001: 2008 requirements in order to meet the stringent performance and reliability criteria required by the following types of industrial operations:

- Pulp and Paper
- Mining
- Steel Mills
- Petrochemical
- Refineries
- Power
- Distilleries, Wineries and Breweries
- Automotive Manufacturing



## Cla-Val Strong

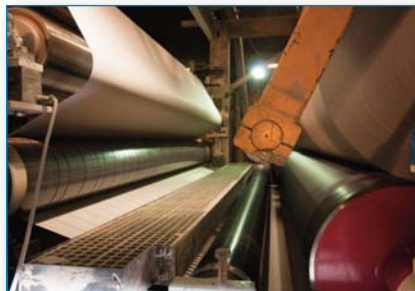

# Cla-Val Statement of Qualifications: Onshore and Offshore Fire Protection

## Cla-Val Fire Protection Industry Experience & Capabilities: Onshore and Offshore Applications



From fire suppression systems in high-rise buildings and industrial facilities to the rigorous demands of fire protection systems aboard offshore oil platforms and FPSOs, Cla-Val products provide accurate and reliable performance in the most critical of services, both onshore and offshore. Applications include fire pump pressure relief; pump suction control, deluge, pressure regulation, air release and backflow prevention. Cla-Val Breach Valves protect life and property by preventing fire suppression water supplies from draining in the event of a catastrophic breach in the piping system.

Available in a wide range of special alloys, relevant Cla-Val products are MEA, UL and ULC listed and have Factory Mutual approval.



**Commercial High-Rise Fire Protection:**  
Breach Control, Pressure Reducing,  
Pressure Increasing, Fire Pump Control,  
Pump Check and Air Release



**Burj Khalifa - Dubai UAE**



**Onshore Industrial Fire Protection:**  
Breach Control, Pressure Reducing,  
Pressure Increasing, Fire Pump Control,  
Pump Check and Air Release



**Seawater Service Fire Protection  
Products for Offshore Platforms  
and FPSOs :**

Deluge, Pressure Reducing,  
Pressure Increasing,  
Fire Pump Control,  
Pump Check and Air Release



# Cla-Val Statement of Qualifications: Aviation Fueling

## Cla-Val Aviation Fueling Industry Experience & Capabilities



Cla-Val control valves, refueling nozzles, couplers and other ground fueling equipment play a vital role in fuel handling systems for both civilian and military aviation. Our ground fueling products meet or exceed all relevant industry approvals such as API, TÜV, STS-M, MIL-N-5877, MS24484 and all applicable ASTM and ANSI standards. Applications include control of fuel at receiving facilities, storage tanks, fuel/water separation stations, distribution/circulation systems and mobile refuelers and aircraft hot refueling.

From hydrant to aircraft, our proven design and quality workmanship makes Cla-Val one of the most trusted names in the commercial and military aviation industries.



Wide Range Pantograph



Commercial Aviation Fueling System - Fuel Storage Tanks



Worldwide Ground Fueling Support



Complete fueling products test facility at factory

## Certifications & Approvals

- API Bulletin 1584, Third Edition - hydrant pit valves
- CE# 0036 for automatic control valves
- AF-System Safety Engineering Analysis – pantographs
- NSN – refueling nozzles
- ATEX – fueling nozzles and control valves



# Cla-Val Statement of Qualifications: Marine Products

## Cla-Val Marine Experience & Capabilities



Cla-Val marine products are designed to meet the exacting requirements of military and commercial shipboard applications. Our automatic control valves are utilized in nearly all of the US Navy's shipboard magazine sprinkler and AFFF fire fighting systems. The military has relied on Cla-Val products for nearly 70 years to protect its personnel in the event of an on-board disaster.

On aircraft carriers, Cla-Val three-way fuel/defuel valves are provided for aircraft fueling and defueling, while other valves control fuel from storage tanks to the flight deck. Additional shipboard applications include cross connection control and lubricating oil pressure control. Specially designed Cla-Val pressure reducing and pressure relief valves are used in seawater systems. Further applications include flow control, solenoid control, and countermeasure wash down, ballasting/de-ballasting and void filling.



**Marine Magazine  
Sprinkler Valve**



**Marine Fueling and  
Defueling Valve**



**Top quality products for the entire fleet:  
Aircraft Carriers, Frigates, Mine Sweepers,  
Assault Ships, Landing Craft, Destroyers,  
and Guided Missile Cruisers**



# Cla-Val Statement of Qualifications: Quality Control • Environmental Health and Safety

## Cla-Val Quality Control Program

All of Cla-Val's manufacturing processes and practices are verified by the procedures outlined in the Cla-Val Quality Control Manual, which dictates inspection points and controls on product as it moves through the manufacturing steps.

Enforced by the Quality Control Manual, the company provides and maintains an inspection system that will assure that all supplies and services submitted conform to contract requirements whether manufactured by Cla-Val; our foundries; processed by the contractor; or procured from subcontractors or vendors.

We also have in-house state-of-the-art testing facilities and equipment at both our foundry and manufacturing operations to further assurance optimum quality in every product we produce



## Quality by Design

## Cla-Val Environmental Health and Safety Program

The Environmental Health and Safety Department is responsible for implementing a program that ensures the health and safety of the company employees and helps minimize environmental impact related to our business operations. The objective the Environmental Health and Safety Program is to prevent personal injury through company-wide adherence to safety procedures and to follow environmental protection measures.

Cla-Val fulfills its mission to create and maintain a safe and environmentally sound workplace by adhering to procedures in the following major areas:

- Hazardous Waste & Materials Management
- Federal, State and Local Regulatory Compliance
- Health & Safety Inspection/Facility Audits
- Accident & Injury Prevention/Investigations
- Education, Training & Protective Equipment
- Safety Standard & Procedures
- Energy Efficient Facility and Systems



# Cla-Val Statement of Qualifications: Technical Documentation

## Supplemental Product and Company Information

Cla-Val has an extensive library of technical, marketing and company documentation to assist our customers in understanding the breadth of our product line and to make carefully considered choices when making product selections.

In addition to documents that are available on our website at [www.cla-val.com](http://www.cla-val.com), existing and potential customers may request hard or digital copies of a wide array of technical data sheets, application overview sheets, product animations, product presentations and brochures by contacting their regional sales office, the authorized sales agent for their area or by contacting any of our factories or global locations.

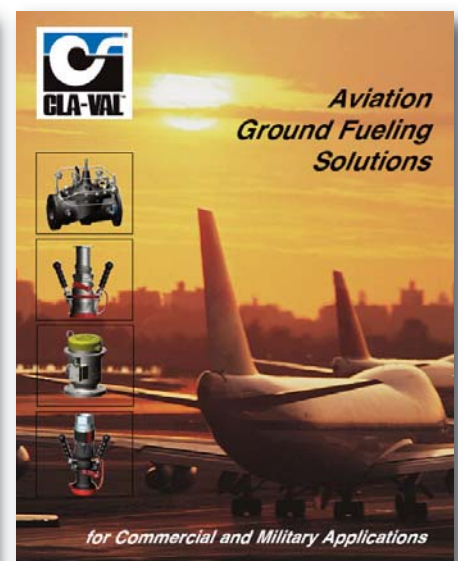
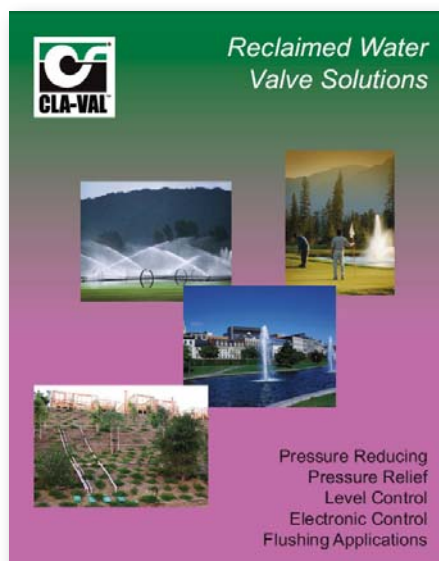
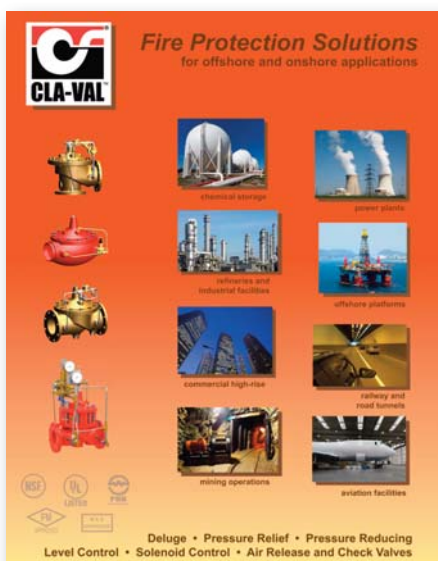
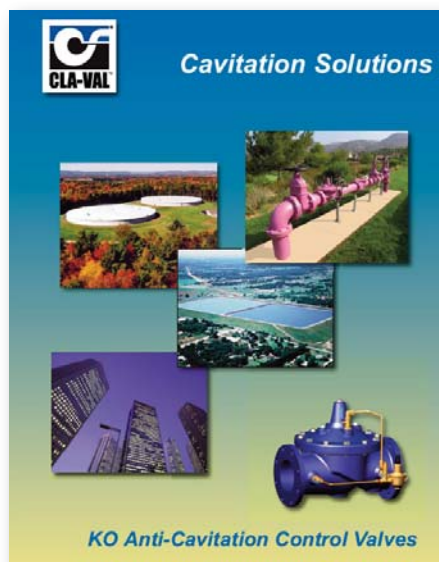



## GLOBAL HEADQUARTERS

1701 Placentia Avenue  
Costa Mesa, CA 92627  
Phone: (949) 722-4800  
800-942-6326  
Fax: (949) 548-5441  
www.cla-val.com  
E-mail: claval@cla-val.com



## US WESTERN REGION

11626 Sterling Avenue, Suite F  
Riverside, CA 92503  
Phone: (951) 687-9145  
800-247-9090  
Fax: (951) 687-9954  
E-mail: lvanderk@cla-val.com

## US SOUTHERN REGION

8707 Forney Road  
Dallas, TX 75227  
Phone: (214) 388-3493  
Fax: (214) 381-9579  
800-533-8181  
Email: tstaats@cla-val.com

## US NORTHERN REGION

P.O. Box 863  
Elgin, IL 60121  
280 Willard Avenue  
Elgin, IL 60120  
Phone: (847) 697-1413  
800-238-7070  
Fax: (847) 697-5549  
E-mail: acaselli@cla-val.com

## US EASTERN REGION

6911 Richmond Highway, Suite 444  
Alexandria, VA 22306  
Phone: (703) 721-1923  
800-451-3030  
Fax: (703) 721-1927  
E-mail: bmoore@cla-val.com

## CLA-VAL EUROPE

Chemin des Mesanges 1  
CH-1032 Romanel/Lausanne Switzerland  
Phone: 41-21-643-15-55 • Fax: 41-21-643-15-50  
E-mail: cla-val@cla-val.ch

## CLA-VAL UK

Dainton House, Goods Station Road  
GB - Tunbridge Wells  
Kent TN1 2 DH England  
Phone: 44-1892-514-400 • Fax: 44-1892-543-423  
E-mail: info@cla-val.co.uk

## CLA-VAL FRANCE

Porte du Grand Lyon 1  
ZAC du Champ du Périon  
France - 01700 Neyron  
Phone: 33-4-72-25-92-93 • Fax: 33-4-72-25-04-17  
E-mail: cla-val@cla-val.fr

## CLA-VAL CANADA

4687 Christie Drive  
Beamsville, Ontario  
Canada L0R 1B4  
Phone: (905) 563-4963 • Fax: (905) 563-4040  
E-mail: sales@cla-val.ca

## CLA-VAL PACIFIC

45 Kennaway Road  
Christchurch, New Zealand, 8023  
Phone: 64-39644860  
Fax: 64-39644876  
Email: gnuthall@cla-val.com

800.942.6236  
www.cla-val.com

CV\_SOQ (01/2014)